

# DRAW WIRE SENSOR



## GX200 SERIES

### Key-Features:

- Multifunctional sensor for extremely rough environments (Position, Velocity, Inclination)
- Suitable for marine and offshore, mining, railway applications, commercial vehicles, and construction machinery
- Suitable for SIL 2 in accordance with DIN EN 61508 and PL d in accordance with EN 13849-1 (for analog and redundant position signals)
- Measurement ranges from 3 to 12 m
- Output signals: potentiometer, current, voltage or CANopen, optional redundant output
- Protection class up to IP69K
- Temperature range -40...+85 °C

### Content

Technical Data .....	2
Position Output - Analog.....	2
Position Output - Digital CANOPEN.....	3
Velocity Output.....	3
Inclination Output .....	4
Technical Drawing .....	4
Accessories.....	5
Options .....	7
Electrical Connection.....	8
Order Code.....	9

## TECHNICAL DATA

Measurement range	[m]	3	4	5	6	7	8	9	10	11	12	
Draw wire diameter	[mm]	1.6 / optional: 1 / 2									1.6 / optional: 1	
Linearity	[%]	±0.15			±0.1 (±0.15 for 5R/10R)							
Resolution		see output types below										
Sensor element		position: potentiometer   velocity: tacho generator   inclination: MEMS										
Measured dimension		Position, optional: velocity, inclination										
Output signals position		potentiometer / 0.5...4.5 V / 0...5 V / 0...10 V / 4...20 mA / CANopen										
Redundant output signals position		optional for: potentiometer / 0.5...4.5 V / 0...5 V / 0...10 V / 4...20 mA / CANopen										
Connection		connector output M12 radial or cable output radial (TPE cable)										
Protection class		IP67/IP69K (only with cable output)										
Humidity		max. 90 % relative, no condensation										
Operating temperature	[°C]	-40...+85										
Shock		DIN EN 60068-2-27:2010, 50 g / 11 ms, 100 shocks per direction, 600 shocks total										
Vibration		DIN EN 60068-2-6:2008, 10 g, 10-2000-10 Hz, 10 cycles										
Acceleration $A_0$	[m/s <sup>2</sup> ]	100										
Extraction force $F_{min}$	[N]	40										
Extraction force $F_{max}$	[N]	45	46	47	48	49	50	51	52	53	54	
Housing		aluminium (EN AW-5083, EN AW-6060, EN AW-6082) seawater-resistant anodised, stainless steel (1.4404 / V4A)										
Draw wire		stainless steel V4A with synthetic coating										
Weight	[kg]	approx. 12										

## POSITION OUTPUT - ANALOG

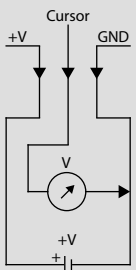
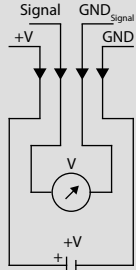
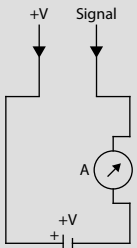
Output type	Potentiometer			Voltage <sup>1)</sup>			Current
Order code	1R	5R	10R	4,5V	5V	10V	420A
Output	1 kΩ	5 kΩ	10 kΩ	0.5...4.5 V	0...5 V	0...10 V	4...20 mA
Supply	max. 30 V			8...30 VDC		12...30 VDC	12...30 VDC <sup>2)</sup>
Recommended cursor current	<1 μA			-			
Current consumption max.	-			max. 25 mA (no load)			-
Power consumption max.	-						
Output current	-			max. 10 mA, min. load 10 kΩ			max. 50 mA in case of error <sup>3)</sup>
Dynamics	-			<3 ms from 0...100 % and 100...0 %			<1 ms from 0...100 % and 100...0 %
Resolution	theoretically unlimited, limited by the noise						
Noise	depends on the quality of the power supply			0.5 mV <sub>eff</sub>			1.6 μA <sub>eff</sub>
Inverse-polarity protection	-			yes			
Short-circuit proof	-			yes			-
Operating temperature	-40...+85 °C						
Temperature coefficient	±0.0025 %/K			0.0037 %/K			0.0079 %/K
EMC	-			according to EN 61326-1:2013			
Circuit							

<sup>1)</sup> Galvanically isolated

<sup>2)</sup> Load: 250 Ω (max. 500 Ω)

<sup>3)</sup> Load max. 0.5 kΩ

## POSITION OUTPUT - DIGITAL CAN<sub>OPEN</sub>

Link to the manual		<a href="#">CANopen (WCAN)</a>
CAN specification		Full CAN 2.0B (ISO11898)
Communication profile		CANopen CiA 301 V 4.2.0
Device profile		Encoder, absolute linear; CIA 406 V 3.2.0
Error control		Producer Heartbeat, Emergency Message, Node Guarding
Node ID		Default: 7, configurable via SDO
PDO		1 x TPDO, static mapping
PDO Modes		Event-triggered, Time-triggered, Sync-cyclic, Sync-acyclic
Transmission rate		1 Mbps, 800, 500, 250, 125, 50, 20 kbps configurable via SDO
Integrated Bus termination resistor		120 $\Omega$ , connectible via SDO
Bus, galvanic separation		No
Supply	[VDC]	8...30
Current consumption		10 mA typical at 24 V, 20 mA typical at 12 V
Measurement rate		1 kHz with 16-bit resolution
Repeatability		equal to the linearity
Resolution		0.002 % of measurement range
Electrical protection		inverse polarity protection
Operating temperature	[°C]	-40...+85
Temperature coefficient	[%/K]	0.0014
EMC		DIN EN61326-1:2013, conformity with directive 2014/30/EU

## VELOCITY OUTPUT

Output	[V/m/s]	1
Standard deviation	[V]	$\pm 1$ % of the output value
Sensor element		Tachometer generator
Speed $V_{\min}$	[mm/s]	10
Tachometer supply		self-sufficiency

## INCLINATION OUTPUT

Output type		Voltage	Current
Measurement range			360°
Repeatability			±0.2°
Resolution			12 bit (0.088°)
Sampling rate			50 Hz (20 ms)
Output		0...10 V	4...20 mA
Supply	[VDC]	15...30	10...30
Current consumption max.	[mA]		40
Short-circuit proof (supply)			yes

### Signal position

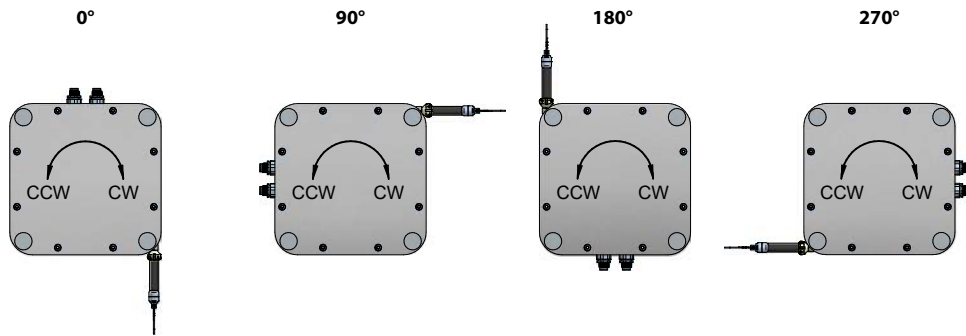

Output	0°		90°		180°		270°	
	NGV	NGA	NGV	NGA	NGV	NGA	NGV	NGA
CW	0 V or 10 V	4 mA or 20 mA	7.5 V	16 mA	5 V	12 mA	2.5 V	8 mA
CCW	10 V or 0 V	20 mA or 4 mA	2.5 V	8 mA	5 V	12 mA	7.5 V	16 mA

## TECHNICAL DRAWING

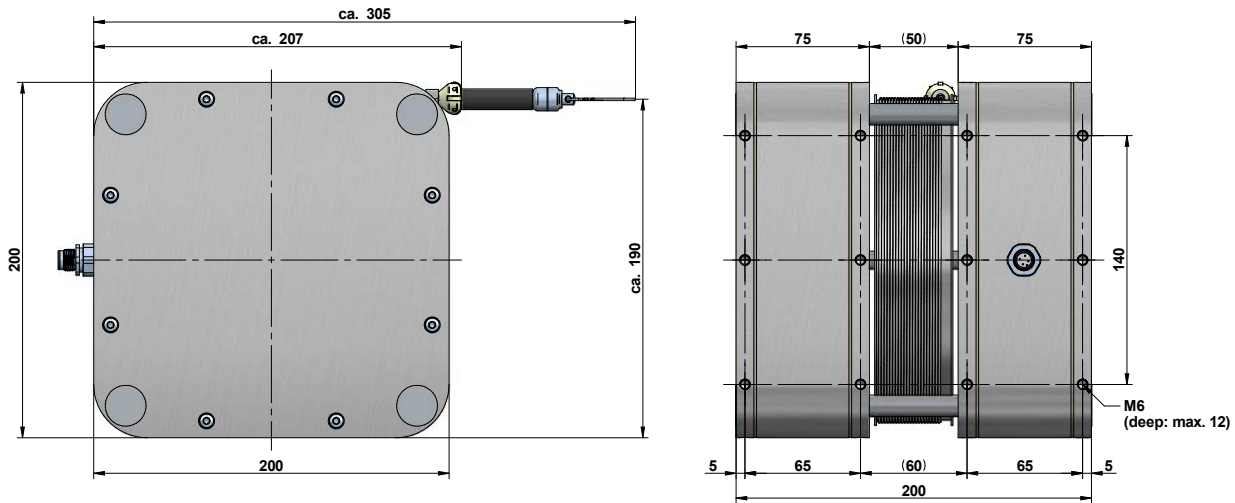

### Position rope outlet for D16K

Measurement range	A (±1)
3	90.5
4	93.5
5	96
6	99
7	102
8	104.5
9	107.5
10	110
11	113

## TECHNICAL DRAWING

Version cable output

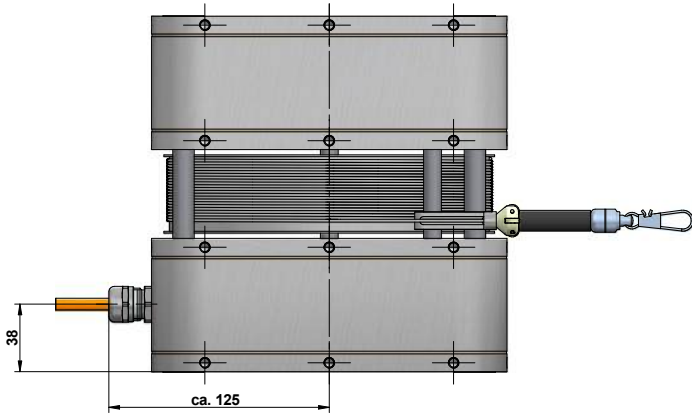

Version velocity / inclination

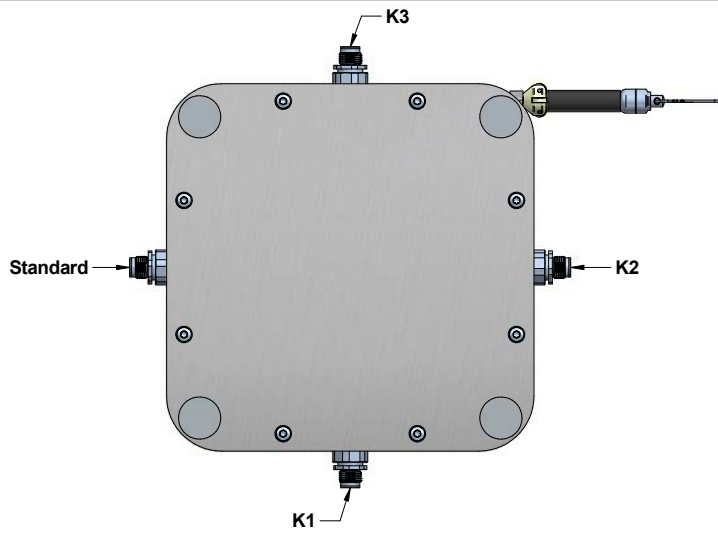
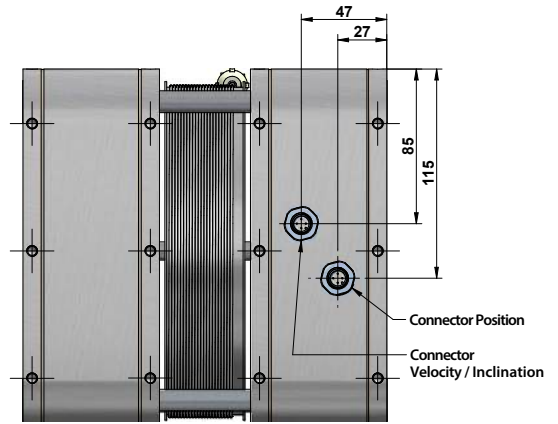

## ACCESSORIES

### Base plate GX200-BP1

Contains the following:

2 x base plate GX200-BP1

8 x washer DIN9021, M8, A4

12 x cylinder head screw DIN7984, M6x14, A4

8 x cylinder head screw DIN912, M8x20, A4

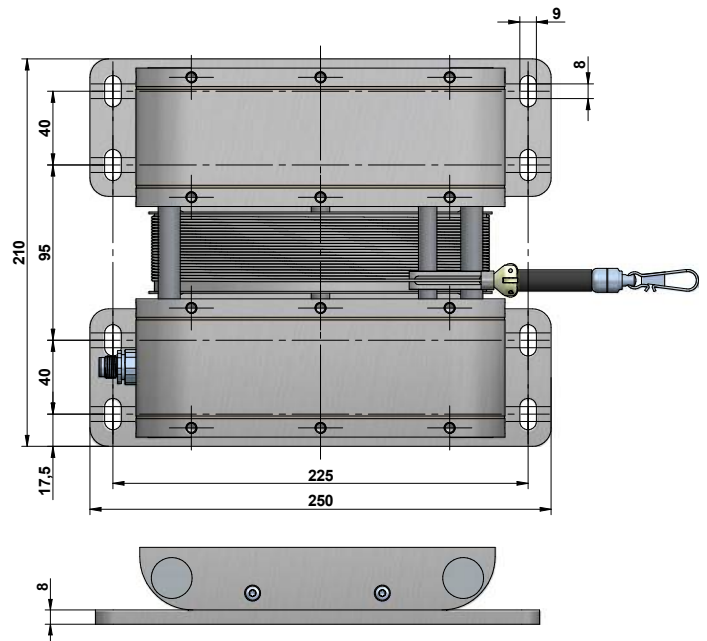
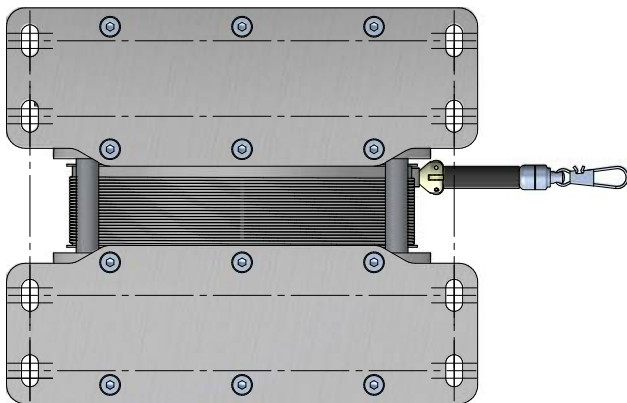

Please note the connector / cable orientation (options K1, K2, K3)!

## ACCESSORIES

### Base plate GX200-BP2

Contains the following:

2 x base plate GX200-BP2

8 x washer DIN9021, M8, A4

12 x cylinder head screw DIN7984, M6x14, A4

8 x cylinder head screw DIN912, M8x20, A4

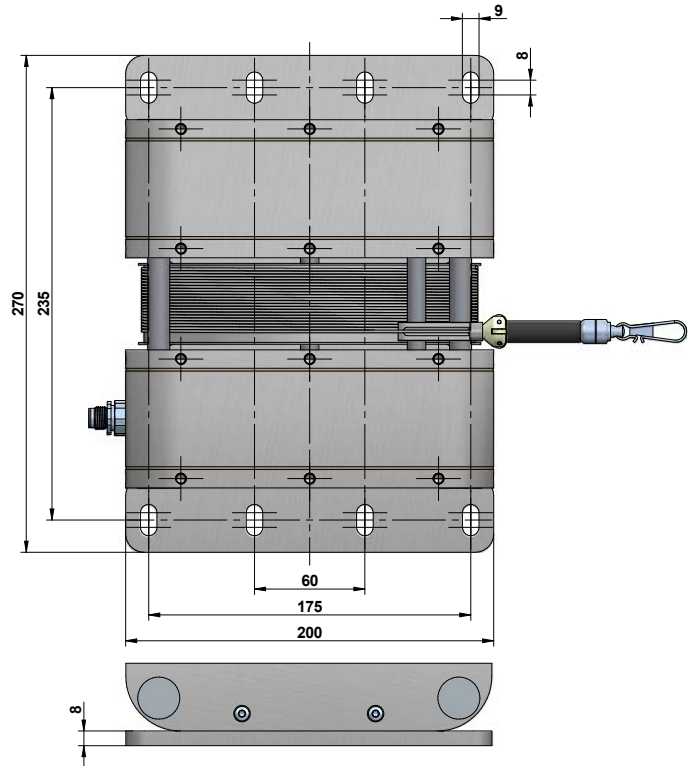
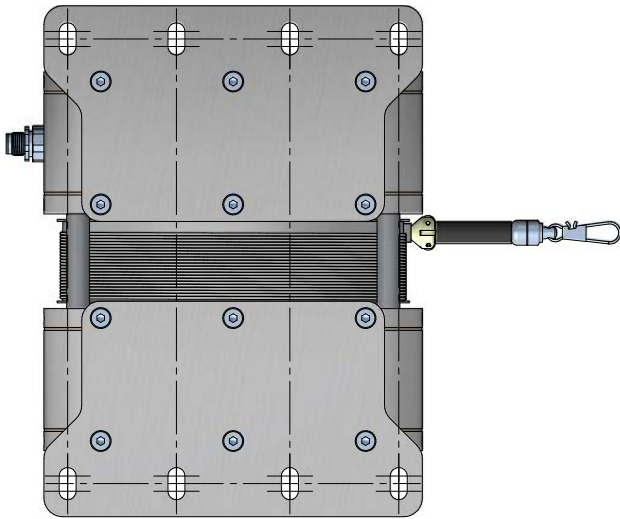

Please note the connector / cable orientation (options K1, K2, K3)!

### Protection plate GX200-PC1

Contains the following:

1 x protection plate GX200-PC1, V4A

6 x cylinder head screw DIN7984, M6x10, A4

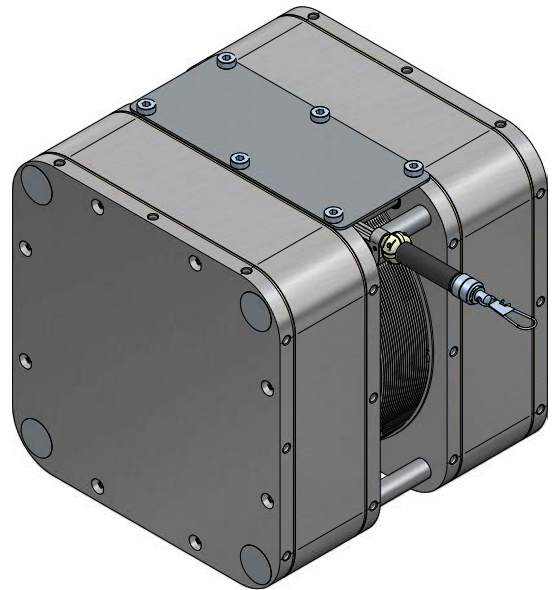
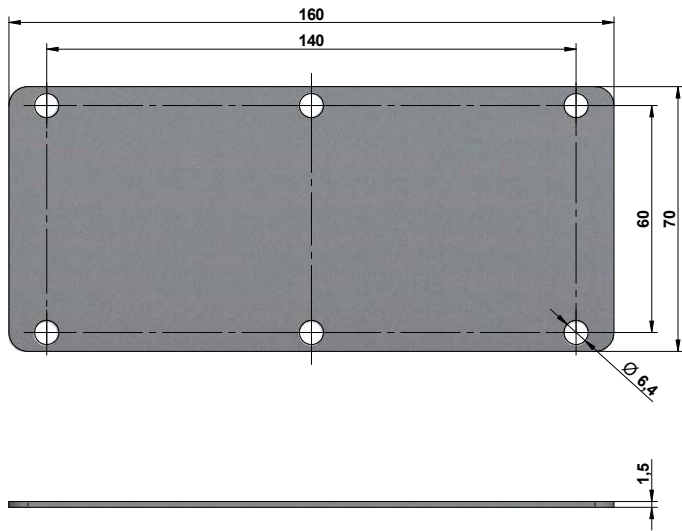

### Ball joint head GX200-GK6 (for rope fixation M6)

Contains the following:

1 x Ball joint head M6, V4A

1 x nut 934, M6, A4

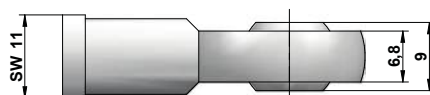
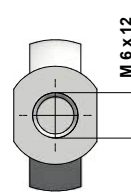
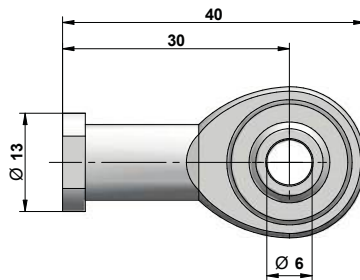

## OPTIONS

Option	Order Code	Description
Changed cable or connector orientation (drawing see page 5)	K1, K2, K3	Rope bridge points to the right: Standard: cable or connector output shows to the left K1: cable or connector output shows downwards K2: cable or connector output shows to the right K3: cable or connector output shows upwards
Inverted output signal (analog position output only, INR with redundant options only)	IN, INR	The analog signal of the sensor is increasing by extracting the rope (standard). Option IN inverts the signal, i.e. the signal of the sensor declines by extracting the rope. IN: inverted output signal (both signals with redundant options) INR: Signals in opposite directions. 1 signal standard, 1 signal inverted (example: 0...10 V and 10...0 V)
Redundant output signal (Position output only)	R1, R2, R3, R4	By using a double potentiometer the sensor delivers two independent output signals. R1: 2 x potentiometer output R2: 2 x voltage output R3: 2 x current output R4: 2 x CANopen
Velocity output	TG	The sensor is equipped with an additional velocity output. Technical data see <a href="#">page 3</a> .
Inclination output	NGV, NGA	The sensor is equipped with an additional inclination output. Technical data see <a href="#">page 4</a> . NGV: output signal 0...10 V NGA: output signal 4...20 mA
Wire rope diameter	D10K, D16K, D20K	The wire rope is made of V4A stainless steel, 1.4401 with a synthetic coating. Please choose the wire rope diameter in part two of the order code. D10K: Ø 1 mm (on request) D16K: Ø 1,6 mm (standard) D20K: Ø 2 mm (on request, not with measurement ranges 11 m and 12 m)
Rope fixation by M6 thread	M6	Optional, pivoted rope fixation with screw thread M4. Ideal for attachment to through holes or thread holes M4.
Rope fixation by eyelet	R20	The end of the wire rope is equipped with an eyelet instead of a rope clip. Inside diameter 20 mm

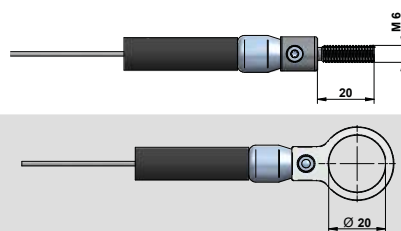
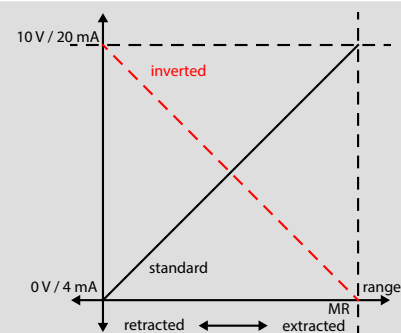

## ELECTRICAL CONNECTION

### Single position output signal

Cable output	Connector output	Potentiometer output	Voltage output	Current output	Connection cable K4P...
BN	Pin 1	+V	+V	+V	BN
WH	Pin 2	Cursor	Signal	n. c.	WH
BU	Pin 3	GND	GND	Signal	BU
BK	Pin 4	n. c.	GND <sub>Signal</sub>	n. c.	BK

Connector , M12 (male)

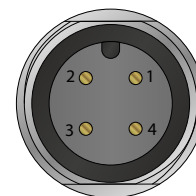

### Redundant position output signal

Cable output	Connector output	Potentiometer output	Voltage output	Current output	Connection cable K8P...
WH	Pin 1	+V <sub>1</sub>	+V <sub>1</sub>	+V <sub>1</sub>	WH
BN	Pin 2	Cursor <sub>1</sub>	Signal <sub>1</sub>	n. c.	BN
GN	Pin 3	GND <sub>1</sub>	GND <sub>1</sub>	Signal <sub>1</sub>	GN
YE	Pin 4	n. c.	GND <sub>Signal, 1</sub>	n. c.	YE
GY	Pin 5	+V <sub>2</sub>	+V <sub>2</sub>	+V <sub>2</sub>	GY
PK	Pin 6	Cursor <sub>2</sub>	Signal <sub>2</sub>	n. c.	PK
BU	Pin 7	GND <sub>2</sub>	GND <sub>2</sub>	Signal <sub>2</sub>	BU
RD	Pin 8	n. c.	GND <sub>Signal, 2</sub>	n. c.	RD

Connector , M12 (male)

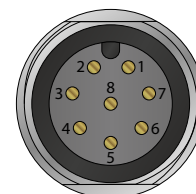

### Digital output CANopen

Information on the CANopen digital output and the corresponding pin assignment can be found in the [CANopen-Manual](#)

### Velocity or Inclination output

Cable output	Connector output	Velocity	Inclination	Connection cable K4P...
BN	Pin 1	n. c.	+V	BN
WH	Pin 2	Signal	Signal CW	WH
BU	Pin 3	n. c.	GND	BU
BK	Pin 4	GND <sub>Signal</sub>	Signal CCW	BK

Connector , M12 (male)

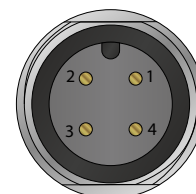

### Velocity and Inclination output

Cable output	Connector output	Function	Connection cable K8P...
WH	Pin 1	+V <sub>Inclination</sub>	WH
BN	Pin 2	Signal CW <sub>Inclination</sub>	BN
GN	Pin 3	GND <sub>Inclination</sub>	GN
YE	Pin 4	Signal CCW <sub>Inclination</sub>	YE
GY	Pin 5	n. c.	GY
PK	Pin 6	Signal <sub>Velocity</sub>	PK
BU	Pin 7	n. c.	BU
RD	Pin 8	GND <sub>Velocity</sub>	RD

Connector , M12 (male)

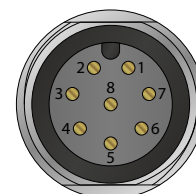

**ORDER CODE**

**GX200** - □ - □ - □ - □ - □

<b>Measurement range MR [m]</b> 3 / 4 / 5 / 6 / 7 / 8 / 9 / 10 / 11 / 12	
---	--

<b>Wire rope</b> Diameter 1 mm (on request) Diameter 1.6 mm (Standard) Diameter 2 mm (on request)	D10K D16K D20K
--	----------------------

<b>Output signal</b>	
Potentiometer 1 kΩ	1R
Potentiometer 5 kΩ	5R
Potentiometer 10 kΩ	10R
Voltage 0.5...4.5 V	4,5V
Voltage 0...5 V	5V
Voltage 0...10 V	10V
Current 4...20 mA	420A
Digital CANopen	WCAN

<b>Connection</b>	
Connector output M12, radial <sup>1)</sup>	SR12
Cable output, radial, 2 m <sup>1)</sup>	KR02
Cable output, radial, 5 m <sup>1)</sup>	KR05
Cable output, radial, 10 m <sup>1)</sup>	KR10

<b>Version</b>	
Standard	-
Sensor with options	O

Option	Description (see page 7)
K1	Cable/connector orientation bottom
K2	Cable/connector orientation right
K3	Cable/connector orientation top
IN	Inverted output signal <sup>2)</sup>
INR	Inverted signals, opposite directions <sup>2), 3)</sup>
R1	Redundant potentiometer output <sup>2)</sup>
R2	Redundant voltage output <sup>2)</sup>
R3	Redundant current output <sup>2)</sup>
R4	Redundant CANopen output <sup>2)</sup>
TG	Velocity sensor
NGV	Inclination sensor 0...10 V
NGA	Inclination sensor 4...20 mA
M6	Rope fixation M6 thread
R20	Rope fixation eyelet

Option	Not combinable with
IN	WCAN
D20K	MR 11/12

<sup>1)</sup> Analog outputs:            4 pole  
 WCAN or Option R4:       5 pole  
 Options R1, R2, R3:       8 pole  
 Option TG or NGV/NGA:   additional 4 pole (see page 5)  
 Options TG and NGV/NGA: additional 8 pole (see page 5)

<sup>2)</sup> Position output only

<sup>3)</sup> INR in combination with R1, R2, R3 or R4 only

## GENERAL ACCESSORIES

GX200-BP1	Base plate version 1	GX200-PC1	Protection plate
GX200-BP2	Base plate version 2	GX200-GK6	Ball joint head for rope fixation M6

## ACCESSORIES CABLES AND CONNECTORS

### Cable with connector (female) M12, 4 poles, shielded, IP67

K4P2M-S-M12	2 m, straight connector
K4P5M-S-M12	5 m, straight connector
K4P10M-S-M12	10 m, straight connector
K4P2M-SW-M12	2 m, angular connector
K4P5M-SW-M12	5 m, angular connector
K4P10M-SW-M12	10 m, angular connector

### Mating connector (female) M12, 4 poles, for self assembly

D4-G-M12-S	straight connector
D4-W-M12-S	angular connector

### Cable with connector (female) M12, 8 poles, shielded, IP67

K8P2M-S-M12	2 m, straight connector
K8P5M-S-M12	5 m, straight connector
K8P10M-S-M12	10 m, straight connector
K8P2M-SW-M12	2 m, angular connector
K8P5M-SW-M12	5 m, angular connector
K8P10M-SW-M12	10 m, angular connector

### Mating connector (female) M12, 8 poles, for self assembly

D8-G-M12-S	straight connector
D8-W-M12-S	angular connector

### Cable with connector (female) M12, 5 poles, shielded, IP67

K5P2M-S-M12	2 m, straight connector
K5P5M-S-M12	5 m, straight connector
K5P10M-S-M12	10 m, straight connector
K5P2M-SW-M12	2 m, angular connector
K5P5M-SW-M12	5 m, angular connector
K5P10M-SW-M12	10 m, angular connector

### Mating connector (female) M12, 5 poles, for self assembly

D5-G-M12-S	straight connector
D5-W-M12-S	angular connector

## ACCESSORIES DISPLAYS

### Digital displays for sensors with analog output, 2 channel

WAY-AX-S	touch screen, supply: 18...30 VDC
WAY-AX-AC	touch screen, supply: 115...230 VAC

Specifications subject to change without prior notice.