

Absolute Encoders with Current Loop or Voltage Output
Series HTA25K

Order Code HTA25K – singleturn, analogue output, not redundant					
Description	Selection: standard= black/bold , possible options= <i>grey/italic</i>				
Series	HTA25K				
Supply voltage / output signal: VSUP=5 V (4.5 to 5.5 V) / OUT=0 to 5 V (<i>ratiometric</i>) VSUP=24 V (15 to 30 V) / OUT=0 to 10 V VSUP=24 V (9 to 30 V) / OUT=4 to 20 mA VSUP=24 V (9 to 30 V) / OUT=0 to 5 V		0505 2410 2442 <i>2405</i>			
Sense of rotation: (when looking at the shaft, from the front) Clockwise <i>Counterclockwise</i>			CW <i>CCW</i>		
Rotation angle* in [°]: 360 <i>320</i> <i>270</i> <i>180</i> <i>90</i> <i>Custom rotation angle (≥7°, positive integer)</i>				360 <i>320</i> <i>270</i> <i>180</i> <i>90</i> <i>XXX</i>	
Electrical connection, cable length: 1 m round cable, axial <i>1 m round cable, radial</i> Plug M8, axial <i>Connector M8, radial</i> <i>Round cable, customer-specific cable length [X,XX m], axial</i> <i>Round cable, customer-specific cable length [X,XX m], radial</i>				PG <i>PGR</i> M8 <i>M8R</i> <i>PGX,XX</i> <i>PGRX,XX</i>	
Installation variant/drilling pattern: Standard version S (Pins for exact alignment optional and not included) <i>Variant P, pins pre-installed on the rotary encoder for precise alignment</i>					S <i>P</i>

* For details see page 26.

Order example HTA25K
Requirements: VSUP=5 V / OUT=0 to 5 V, sense of rotation CW, rotation angle 360°, round cable 1.00 m, mounting using M4 screws only
Example for order code: HTA25K 0505 CW360 PG S

Absolute Encoders with Redundant Voltage Output

Series HTA25KX

Series HTA25KX – singleturn, analogue output, redundant

Key features HTA25KX :

Independent signal processing. The HTA25KX rotary encoder electronics are based mainly on one Hall IC in which two semiconductor dies independently capture, evaluate and output the measured values
 Supply voltage, signal output and ground are galvanically insulated => separate electrical connections
 Supply voltages: 2 x 5 VDC or 2 x 15 to 30 VDC
 Signal outputs: 2 x 0 to 5 V or 2 x 0 to 10 V

Electrical data HTA25KX – singleturn, analogue output, redundant

Effective electrical angle of rotation 1.)	7° ≤ α ≤ 360° (programmable at factory), ±0.5°	
Independent linearity (best straight line) 1.)	±0.3% @ 360°	
Absolute Linearity 1.)	±0.6% @ 360°	
Output signal	0 to 5 V ratiometric	0 to 10 V
Resolution	12 Bit	
Update rate	200 μs	
Supply voltage	5 V ±10%	15 to 30 V
Power consumption (no load)	≤ 23 mA	
Output load	≥ 5 kOhm	
Insulation voltage 1.)	1000 VAC @ 50 Hz, 1 min	
Insulation resistance 1.)	2 MOhm @ 500 VDC, 1 min	
MTTF (EN29500-2005-1)	613a	202a

1.) According IEC 60393

Cable and pin assignment HTA25KX – singleturn, analogue output, redundant

Function:	Option PG(R)	Option M8(R)
VSUP 1	red	1
OUT 1	brown	2
GND 1	black	3
GND 2	green	4
OUT 2	yellow	5
VSUP 2	orange	6
n/c	-	7
n/c	-	8

Plug M8 (R) – pin assignment for 8-pin connector

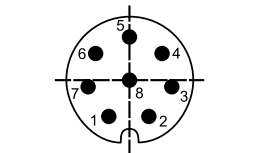

Pin-Numbering of socket connector in the encoder housing

The orientation of the connector relative to the encoder housing is not defined and differs from one encoder to the next. When using angled connectors in combination with axial outlet, the orientation of the cable outlet is thus not defined.

If you need a defined orientation of the cable outlet, please choose our housings with radial cable outlet and use straight mating connectors.

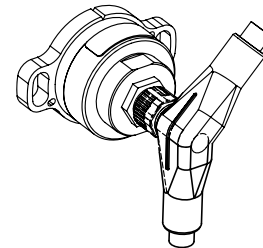

Orientation will vary when using angled connectors.

Absolute Encoders with Redundant Voltage Output
Series HTA25KX

Order Code HTA25KX – redundant, singleturn, analogue output					
Description	Selection: standard= black/bold , possible options= <i>grey/italic</i>				
Series	HTA25KX				
Supply voltage / output signal: VSUP=5 V (4.5 to 5.5 V) / OUT=0 to 5 V (<i>ratiometric</i>) VSUP=24 V (15 to 30 V) / OUT=0 to 10 V	0505 2410				
Sense of rotation: (when looking at the shaft, from the front) Clockwise/Clockwise (ganging) <i>Clockwise/Counterclockwise (counterrotational)</i>		CW CW <i>CW CCW</i>			
Rotation angle* in [°]: 360 <i>320</i> <i>270</i> <i>180</i> <i>90</i> <i>Custom rotation angle (≥7°, positive integer)</i>			360 <i>320</i> <i>270</i> <i>180</i> <i>90</i> <i>XXX</i>		
Electrical connection, cable length: 1 m round cable, axial <i>1 m round cable, radial</i> Plug M8, axial <i>Connector M8, radial</i> <i>Round cable, customer-specific cable length [X,XX m], axial</i> <i>Round cable, customer-specific cable length [X,XX m], radial</i>				PG <i>PGR</i> M8 <i>M8R</i> <i>PGX,XX</i> <i>PGRX,XX</i>	
Installation variant/drilling pattern: Standard version S (Pins for exact alignment optional and not included) <i>Variant P, pins pre-installed on the rotary encoder for precise alignment</i>					S <i>P</i>

* For details see page 26.

Order example HTA25KX – redundant, singleturn, analogue output
Requirement: Redundant, VSUP=5 V /OUT=0...5 V, signal 1 sense of rotation CW, signal 2 sense of rotation CW, electrical rotation 360° signal 1 and 2, M8 plug radial, 8 pin, installation type P (drilling pattern P)
Example for order code: HTA25KX 0505 CW CW 360 M8R P

Drawings HTx25K – Drilling patterns S and P

Dimensions Sensor head for Version with drilling pattern S
(pins optional, to be set by customer)

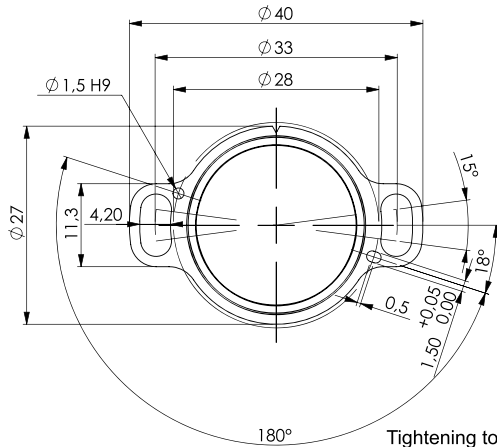

Deviations of variant with drilling pattern P
(cylindrical pins part of the rotary encoder)

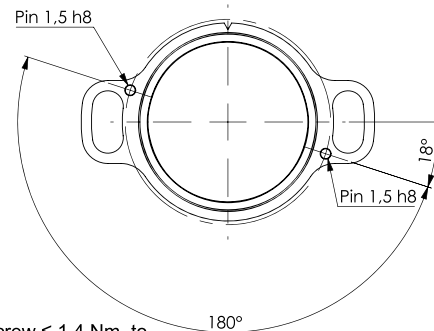

Bohrbild S

Tightening torque of M4 screw ≤ 1.4 Nm, to be locked by medium strength threadlocking adhesive if required

Bohrbild P

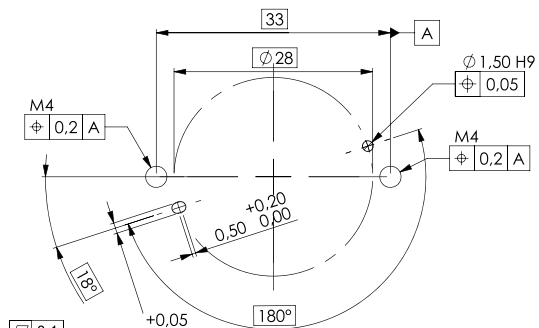
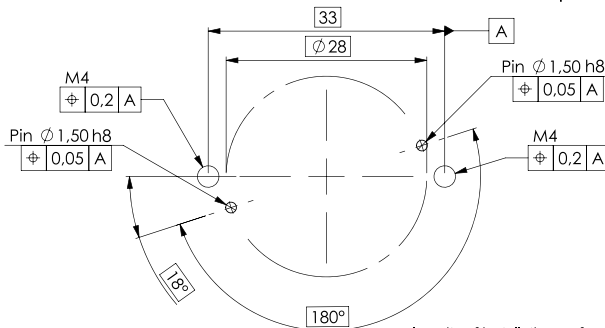

planarity of installation surface $\square 0,1$
roughness of installation surface $\sqrt{Ra 6,3}$

Alle dimensions in mm

Accessories – Sealing ring



O-ring, part no. 133324
DIN 3771-22x1-NBR 70
For sealing between sensor front and mounting surface,
Not included in delivery, please order separately

All dimensions in mm

Drawings HTx25K – Versions for drilling pattern S, magnet positioning

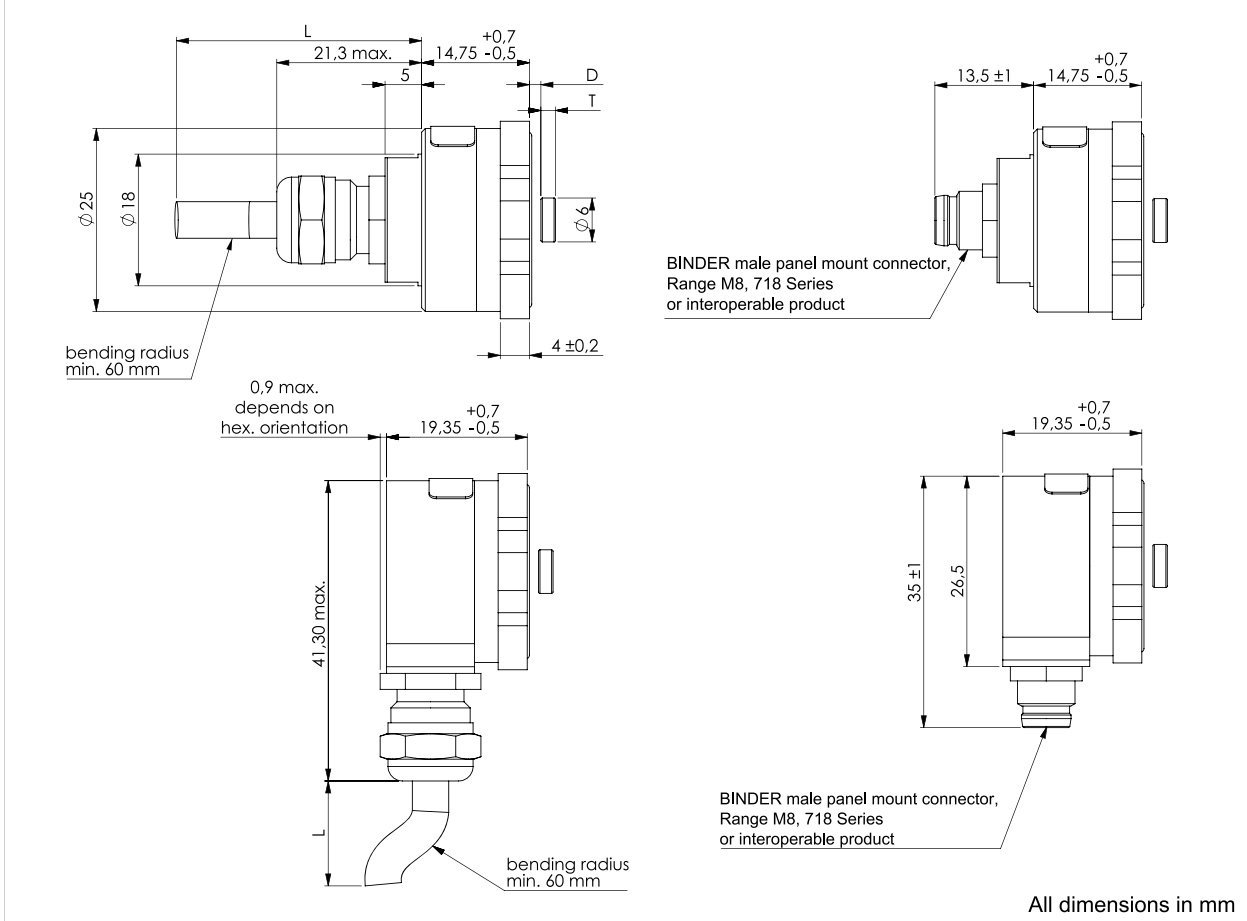

Magnet selection and positioning for enclosed standard NdFeB magnets

Important note:

The correct mounting distance D as well as the correct positioning of the in relation to the central axis to the housing surface of the kiten-coder is mandatory for its correct function. The values below are not valid for other magnets (e. g. accessories).

Magnet thickness and distance from sensor surface		
Electronics	Thickness T of the magnet	Mounting distance D
Analogue singleturn not redundant, HTA25K, HTP25K, HTS25K (only SPI)	3 mm	1.50 +/- 0.15 mm
Serial, not redundant, SPI, (HTS25K)	3 mm	1.50 +/- 0.15 mm
Serial, not redundant, SSI, (HTS25K)	please contact us	
Serial, not redundant, SER, HTS25K (SER)	2 mm	1.00 +/- 0.15 mm
Analogue/serial redundant, HTA25KX, HTS25KX	2.5 mm	0.50 +/- 0.15 mm
Incremental, HTI25K	4 mm	0.50 +/- 0.15 mm
Analogue multi turn HTA25KPM	4 mm	1.00 +/- 0.15 mm

Drawings HTx25K – Deviations for drilling pattern P

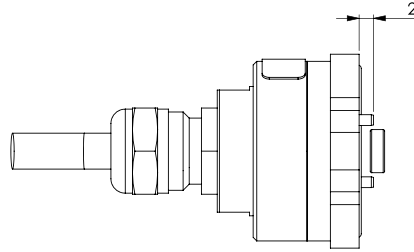

Pins/cylindrical pins are only pre-assembled if drilling hole pattern P is selected.
Missing dimensions see drawings of the variants for hole pattern S.

Drawings – Cable/connector exit direction for radial versions (M8R, PGR)

view shows cable orientation

view shows connector position

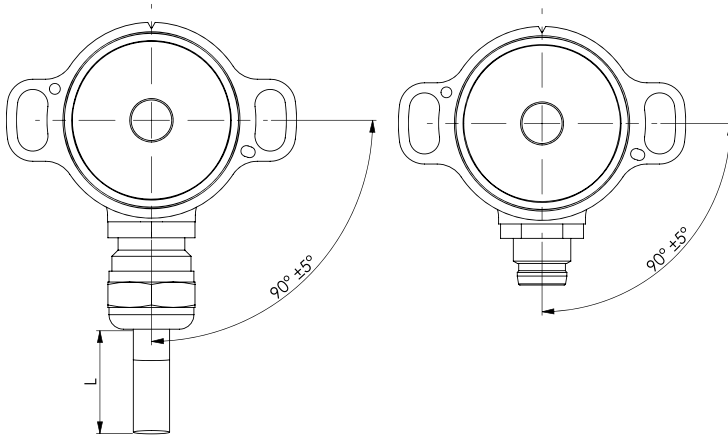

The orientation of the M8 connector pins relative to the encoder housing is not defined and differs from one encoder to the next. When using angled connectors in combination with axial outlet, the orientation of the cable outlet is thus not defined.

If you need a defined orientation of the cable outlet, please choose our housings with radial cable outlet and use straight mating connectors.

Cable specs for option PG(R) (round control cable)

Option	Standard cable length L	Number of single strands (depends on electronics)	Cable sheath Ø or width	Single strands cross section	Allowed tolerance (L)	Minimum bending radius
PG PGR	Standard 1000 mm	3		AWG26	-20 mm to +40 mm	10 x D Ø (D = cable sheath diameter Ø)
		6				
		8				
		10		AWG28		
		12				

Cables delivered with cable shield

(*) Tolerances according IPC Association

Cable length tolerances – custom lengths

Length L	Tolerance
≤ 0.3 m	+25 mm / -20 mm
> 0.3 m - 1.5 m	+40 mm / -20 mm
> 1.5 m - 3 m	+100 mm / -40 mm
> 3 m - 7.5 m	+150 mm / -60 mm

Wire harness length measured from sensor face including connector. Minimum cable length: 0.08 m (for round cable). Please contact us for lengths > 3 m regarding handling and packaging.

Mechanical Data
Family HTx25K

Mechanical and Environmental data	
Mechanical angle of rotation 1.)	Endless
Lifetime 2.)	Mechanically unlimited
Max. operational speed (with shaft sealing)	The maximum actuation speed is not limited mechanically. The maximum permissible actuation speed [rev./min] is calculated in relation to the resolution. For absolute encoders:
	$rev./min. (@max. resolution) = \frac{1}{2^{\frac{Resolution\ in\ bits}{2}} * Update\ rate\ in\ s}} * 60s$
	For incremental encoders:
	$Max. rev./min. = \frac{Limit\ Frequency\ \frac{1}{s} * 60s}{Number\ of\ Pulses}$
Operating temperature range	Option M8 (connector) ③ -30 to +80°C Option PG (cable gland incl. cable) ③ -30 to +85°C cable fixed ③ -10 to +85°C cable in movement
Storage temperature range	-30 to +105°C
Protection grade (IEC 60529) front side	IP67
Protection grade (IEC 60529) rear side	Option PG: IP68 (cable ends excluded) Option M8: IP67 (when mated with IP67 type M8 cable)
Vibration (DIN EN 60068-2-64:2008 + A1: 2019)	±1.5 mm / 30 g / 10 to 2000 Hz / 16 frequency cycles (3x4 h)
Shock (DIN EN 60068-2-27)	400 m/s ² / 6 ms / half sine (100±5) shocks
Housing diameter	Ø 25 mm
Housing depth	In dependency to the electrical connection position: ③ axial 28.25 mm (variant with M8 connector) ③ radial 19.35 mm (variant with M8 connector)
Shaft diameter	No limitation (customer side)
Masse (zirka)	HTx25K with connector M8(R), xx g HTx25K with cable gland and 1 m signal cable PG(R), xx g

1.) According IEC 60393

2.) Determined by climatic conditions according to IEC 68-1, para. 5.3.1 without load collectives

Immunity / Electrostatic Discharge / REACH / RoHS

EN 61000-4-3 RF sine wave	Class A
EN 61000-4-6 Conducted sine wave	Class A
EN 61000-4-8 Power frequency magnetic fields	Class A
EN 61000-4-2 ESD	Class B
REACH Regulation (EC) 1907/2006 including the SVHC list	
RoHS Directive 2011/65/EU	

Mechanical and environmental data, miscellaneous

Sensor mounting	Standard mounting is done by using M4 screws. A rotation of +/- 7.5° is possible to find the zero point in the application when installing the magnet. Alternatively, it is possible to align the rotary encoder exactly to the magnet using cylindrical pins (1.5 mm) in the application (a rotation is then not possible, however). There are two variants/two drilling patterns to choose from: Ⓢ Variant S (standard): Cylindrical pins are installed by the customer in the application and the rotary encoder is attached and fixed using M4 screws Ⓟ Variant P: Cylindrical pins are pre-installed on the rotary encoder. The drillings for the pins must be implemented on the mounting position in the application. This variant is suitable, for example, for mounting on thin sheet metal.
Mounting hardware included	none (Note: With hole pattern P, the cylinder pins are already fixed on the rotary encoder)
Fastening torque per screw for fastening of the rotary encoder	≤ 1.4 Nm (M4 screws, thread tensile strength class 5.6) For screw securing, the use of a medium-strength thread securing adhesive is recommended
Material shaft	Stainless steel
Material housing	Aluminium
Material cable gland (PG)	Stainless steel
Material connector M8	CuZn nickel-plated



Mounting example of the variant for drilling pattern S
Mount using 2 M4 screws, optional exact alignment using 2 cylindrical pins h8 1.5 (e.g. ISO 2338 B) (screws and pins not included)



Mounting example of the variant for drilling pattern P:
Mount using 2 M4 screws, exact alignment is ensured using cylindrical pins h8 1.5 pre-assembled at encoder (screws not included)

Definition of the zero position

Output at the zero point:

HTA25K (analogue outputs): Output signal 0% full scale (F. S.)

HTP25K (PWM output): duty cycle 10% (10% duty cycle)

HTS25K (serial output): Output signal 0% full scale (F. S.), for option 05SER no zero point alignment is available ex works

HTI25K (incremental output): The index signal is output (Z)

The position of the zero position cannot be mechanically defined due to the rotationally symmetrical magnet.
The sense of rotation is defined when looking at the flat front of the rotary encoder:

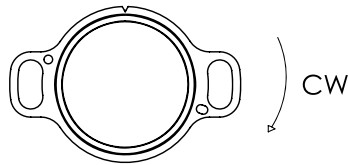

Signal definition for custom rotation angles

Custom angles <math><360^\circ</math>

When programming the electrical angle of rotation of <math><360^\circ</math>, the remaining non-effective range of rotation is divided equally into high and low.

