

# DRAW WIRE SENSOR

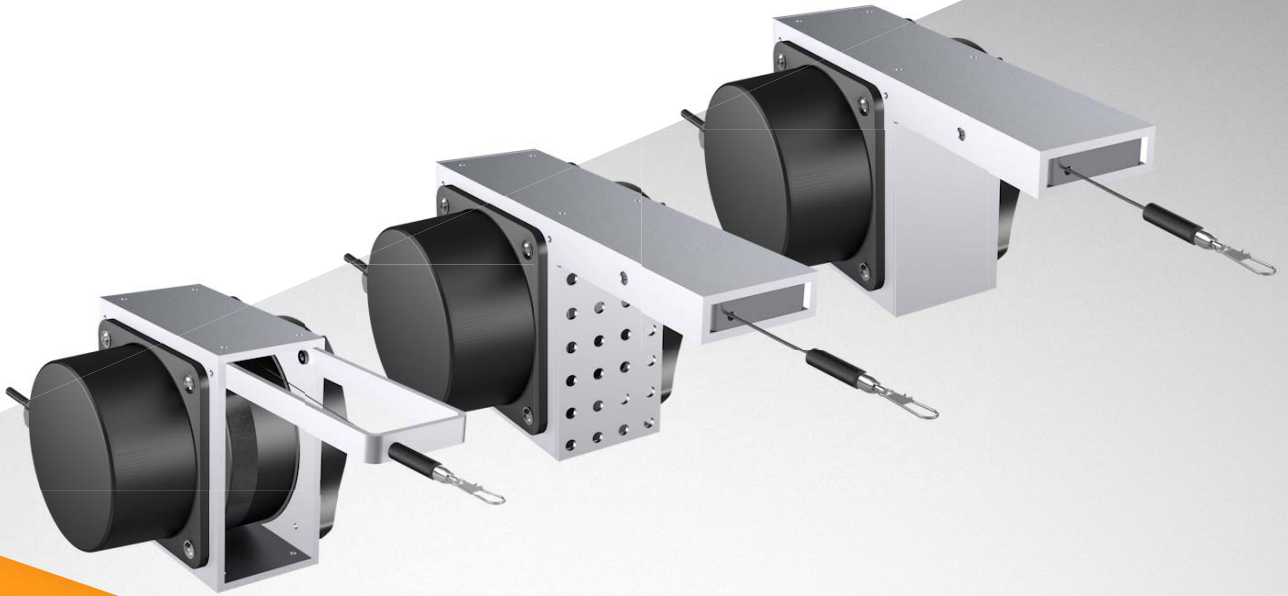

## MH120 SERIES

### Key-Features:

- Cost-effective sensor for construction machinery and mobile hydraulics
- Extreme robust construction
- Five housing variations for different environments
- Measurement ranges from 3 to 10 m
- Linearity up to  $\pm 0.1$  % of full scale
- Output signals: potentiometer, current, voltage or CANopen, optional redundant output
- Teachable outputs: 0...5 V, 0...10 V
- Protection class up to IP69K (suitable for steam and high pressure cleaning)
- Temperature range -20...+85 °C (optional -40 °C)
- Optional with TEDS connector

### Content

<b>Technical Data</b> .....	<b>2</b>
<b>Analog Outputs</b> .....	<b>2</b>
<b>Digital Output CANOPEN</b> .....	<b>3</b>
<b>Housing Variants</b> .....	<b>3</b>
<b>Technical Drawing</b> .....	<b>4</b>
<b>Options</b> .....	<b>6</b>
<b>Accessories</b> .....	<b>7</b>
<b>Applications</b> .....	<b>7</b>
<b>Order Code</b> .....	<b>8</b>

## TECHNICAL DATA

Measurement range	[m]	3	4	5	6	7	8	9	10	
Draw wire diameter	[mm]	0.5 / 1 / 1.5			0.5 / 1			0.5		
Linearity	[%]	±0.25								
Improved linearity (optional)	[%]	±0.1								
Resolution		see output types below								
Sensor element		potentiometer								
Output signals <sup>1)</sup>		potentiometer / 0.5...4.5 V / 0...5 V / -5...+5 V / 0...10 V / 0...5 V (teachable) / 0...10 V (teachable) / 4...20 mA / CANopen								
Redundant output signals		optional for: potentiometer / 0.5...4.5 V / 0...5 V / -5...+5 V / 0...10 V / 4...20 mA / CANopen								
Connection		connector output M12 radial or cable output radial (TPE cable)								
Protection class		IP67, optional IP69K (only in combination with cable output)								
Humidity		max. 90 % relative, no condensation								
Operating temperature		see output types below								
Rope extraction speed	[m/s]	max. 3								
Acceleration	[m/s <sup>2</sup> ]	max. 50								
Extraction force	[N]	$F_{\min} = 7 / F_{\max} = 13$ (depending on the measurement range)								
Housing		aluminium, spring case PA6								
Draw wire		stainless steel V4A								
Weight	[g]	1300 to 1600 (depending on the measurement range)								

<sup>1)</sup> other output signals on request

## ANALOG OUTPUTS

Output type	Potentiometer			Voltage <sup>1)</sup>				Current	Voltage (teachable)		
	1R	5R	10R	4,5V	5V	55V	10V	420A	5VT	10VT	
Order Code	1R	5R	10R	4,5V	5V	55V	10V	420A	5VT	10VT	
Output	1 kΩ	5 kΩ	10 kΩ	0.5...4.5 V	0...5 V	-5...+5 V	0...10 V	4...20 mA	0...5 V	0...10 V	
Supply	max. 30 V			8...30 VDC			12...30 VDC	12...30 VDC <sup>2)</sup>	8...35 VDC		
Recommended cursor current	<1 μA							-			
Current consumption max.	-			max. 25 mA (no load)				-			
Power consumption max.				-				max. 200 mW			
Output current	-			max. 10 mA, min. load 10 kΩ				max. 50 mA in case of error <sup>3)</sup>		max. 10 mA, min. load 1 kΩ	
Dynamics	-			<3 ms from 0...100 % and 100...0 %				<1 ms from 0...100 % and 100...0 %		1 ms	
Resolution	theoretically unlimited, limited by the noise										
Noise	depends on the quality of the power supply			0.5 mV <sub>eff</sub>				1.6 μA <sub>eff</sub>		2 mV <sub>eff</sub>	
Inverse-polarity protection	-			yes						-	
Short-circuit proof	-			yes				-		yes	
Operating temperature	-20...+85 °C / optional: -40...+85 °C										
Temperature coefficient	±0.0025 %/K			0.0037 %/K				0.0079 %/K		0.0016 %/K	
EMC	-			according to EN 61326-1:2013							
Circuit											

<sup>1)</sup> Galvanically isolated

<sup>2)</sup> Load: 250 Ω (max. 500 Ω)

<sup>3)</sup> Load max. 0.5 kΩ

MFL = multi-functional line

## DIGITAL OUTPUT CA

Link to the manual		<a href="#">CANopen (WCAN)</a>
CAN specification		Full CAN 2.0B (ISO11898)
Communication profile		CANopen CiA 301 V 4.2.0
Device profile		Encoder, absolute linear; CIA 406 V 3.2.0
Error control		Producer Heartbeat, Emergency Message, Node Guarding
Node ID		Default: 7, configurable via SDO and Squeezer (offline configuration) <sup>1)</sup>
PDO		1 x TPDO, static mapping
PDO Modes		Event-triggered, Time-triggered, Sync-cyclic, Sync-acyclic
Transmission rate		1 Mbps, 800, 500, 250, 125, 50, 20 kbps configurable via SDO and Squeezer (offline configuration) <sup>1)</sup>
Integrated Bus termination resistor		120 Ω, connectible via SDO and Squeezer (offline configuration) <sup>1)</sup>
Bus, galvanic separation		No
Supply	[VDC]	8...30
Current consumption		10 mA typical at 24 V, 20 mA typical at 12 V
Measurement rate		1 kHz with 16-bit resolution
Repeatability		equal to the linearity
Resolution		0.002 % of measurement range
Electrical protection		inverse polarity protection
Operating temperature	[°C]	-20...+85 / optional: -40...+85
Temperature coefficient	[%/K]	0.0014
EMC		DIN EN61326-1:2013, conformity with directive 2014/30/EU

<sup>1)</sup> For more information on the offline configuration please refer to the [CANopen manual](#).

## HOUSING VARIANTS

**Standard: open housing and open rope bridge**

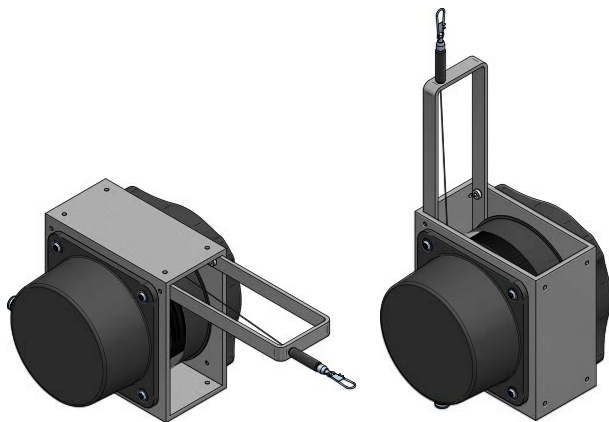

**Variant C1: perforated plate covering and open rope bridge**

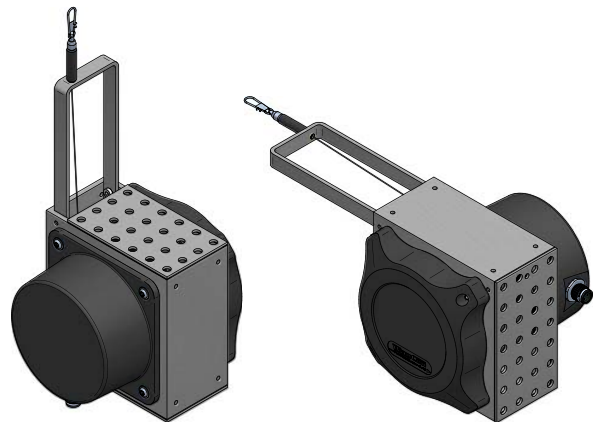

**Variant C2: perforated plate covering and closed rope bridge**

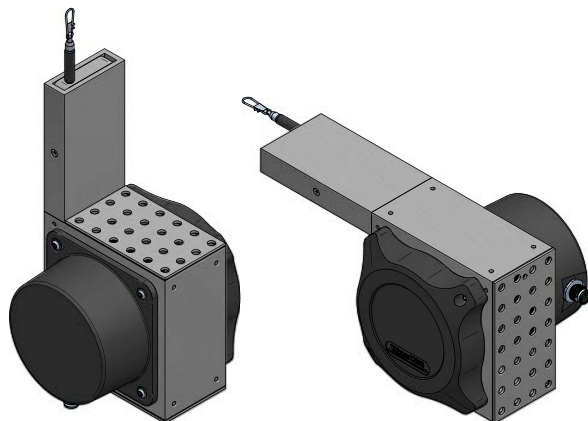

**Variant C3: closed housing and closed rope bridge**

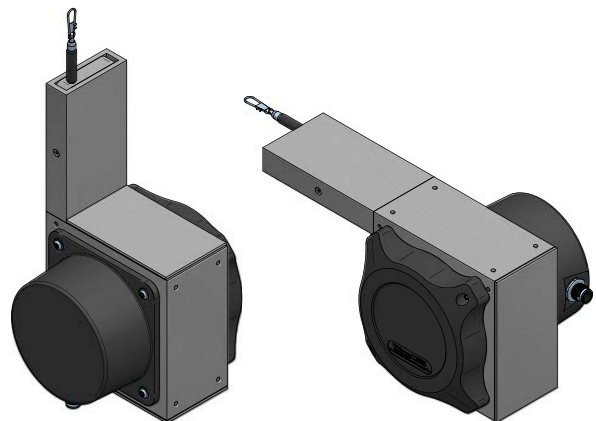

## TECHNICAL DRAWING

### Standard housing variant: open housing and open rope bridge

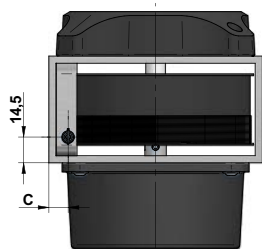
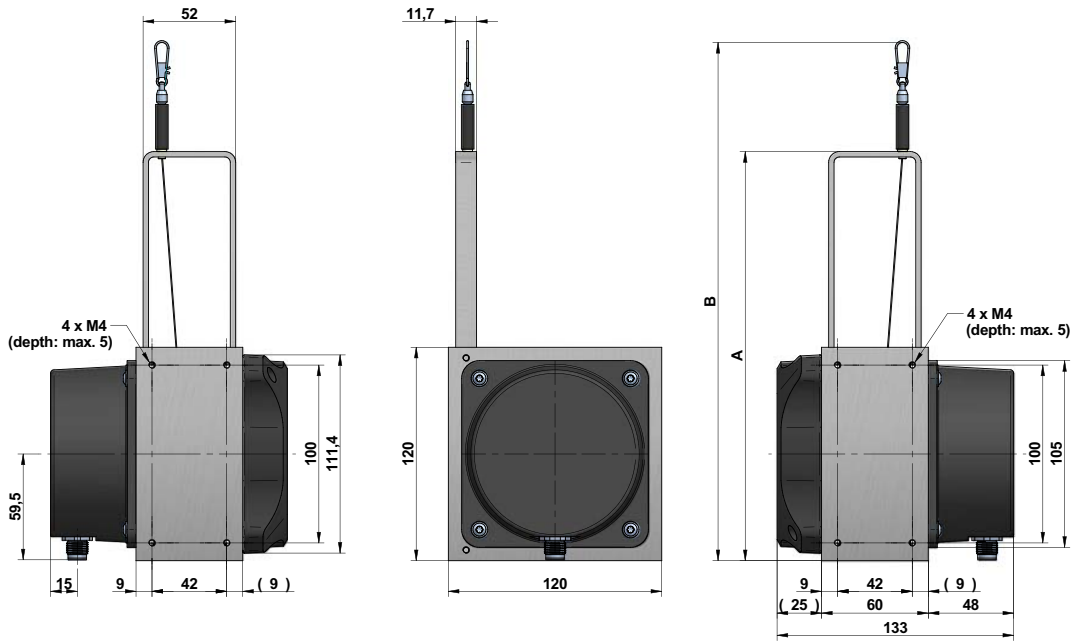

Rope diameter ▶	Ø 0.5 mm			Ø 1 mm			Ø 1.5 mm		
Range ▼	A	B	C	A	B	C	A	B	C
3 m	230	~291.5	10.75	230	~291.5	10.75	230	~291.5	10.75
4 m	230	~291.5	10.75	230	~291.5	10.75	230	~291.5	10.75
5 m	230	~291.5	10.75	230	~291.5	10.75	320	~381.5	12.25
6 m	230	~291.5	10.75	320	~381.5	12.25	320	~381.5	12.25
7 m	230	~291.5	10.75	320	~381.5	12.25	-	-	-
8 m	230	~291.5	10.75	320	~381.5	12.25	-	-	-
9 m	230	~291.5	10.75	-	-	-	-	-	-
10 m	230	~291.5	10.75	-	-	-	-	-	-

### Connector output / cable output all variants

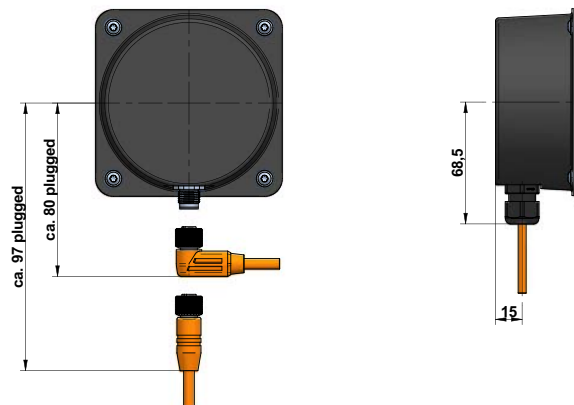

Note: when using close-range high pressure or high temperature spray downs for cleaning purposes the cable must be protected.

## TECHNICAL DRAWING - VARIATIONS

### Option C1: perforated plate covering and open rope bridge

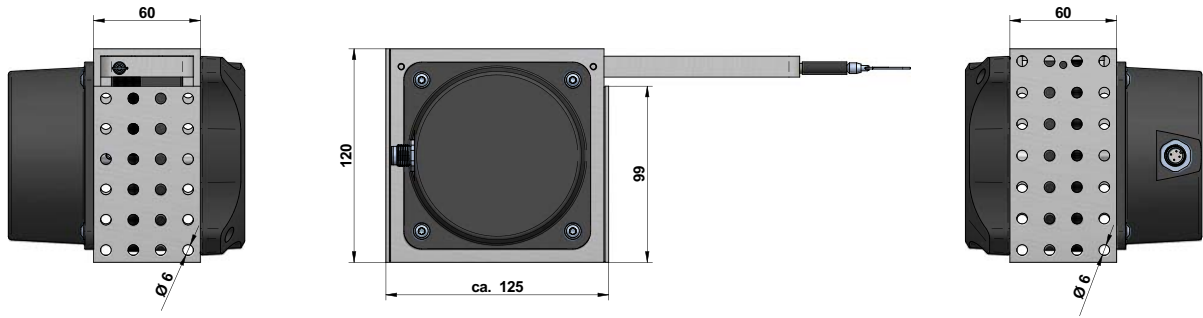

### Option C2: perforated plate covering and closed rope bridge

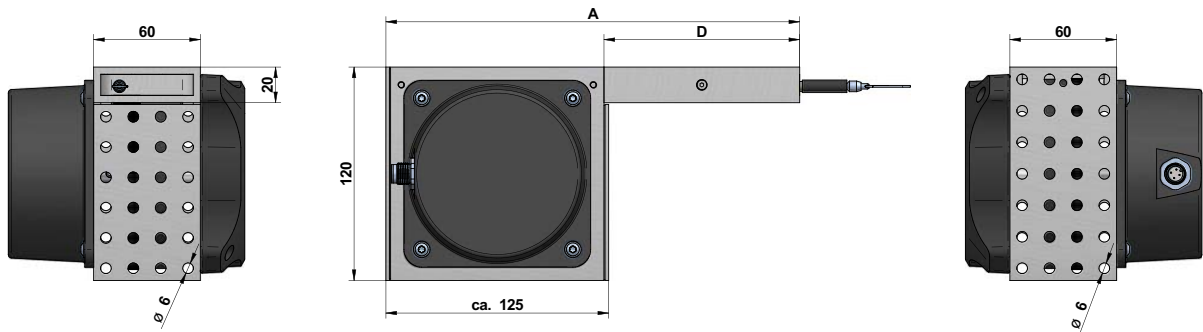

### Option C3: closed housing and closed rope bridge

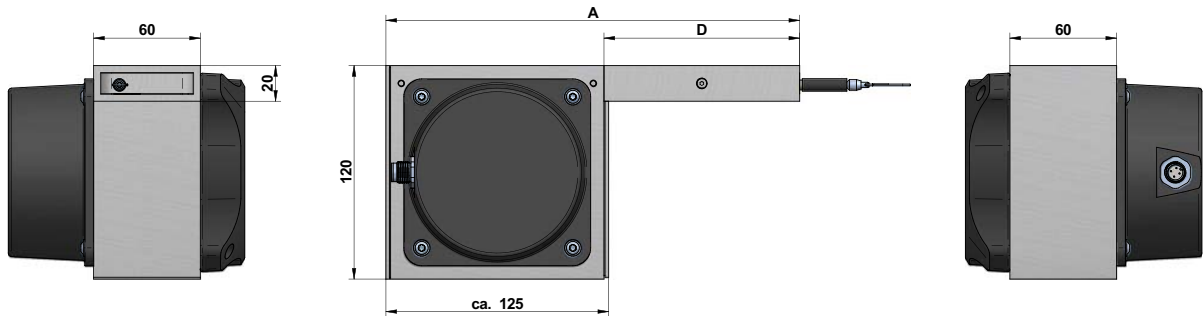

Rope diameter ▼	Range ►	3 m	4 m	5 m	6 m	7 m	8 m	9 m	10 m
Ø 0.5 mm	A	233							
	D	110							
Ø 1 mm	A	233			323			-	
	D	110			200			-	
Ø 1.5 mm	A	233		323		-			
	D	110		200		-			

### Option IAP: seawater protection

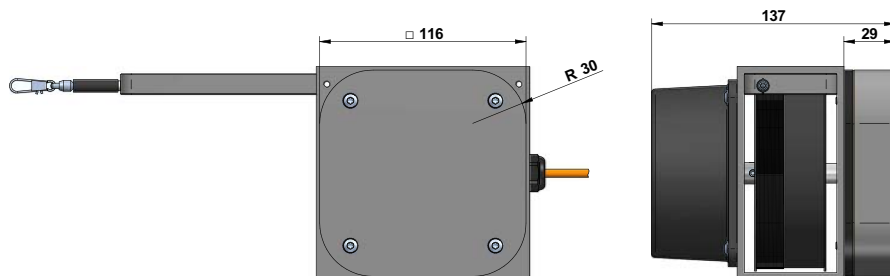

### Options K1, K2, K3: changed cable or connector output

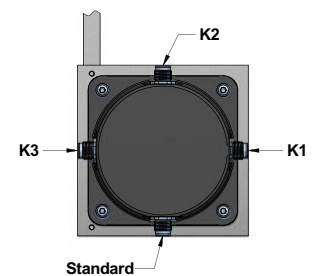

## OPTIONS

Option	Order code	Description
Changed cable or connector orientation (drawing see <a href="#">page 5</a> )	K1, K2, K3	Rope bridge points upwards: Standard: cable or connector output shows downwards K1: cable or connector output shows to the right K2: cable or connector output shows upwards K3: cable or connector output shows to the left
Improved linearity	L10	Improved linearity 0.1 %
Inverted output signal (analog output only)	IN	The analog signal of the sensor is increasing by extracting the rope (standard). Option IN inverts the signal, i.e. the signal of the sensor declines by extracting the rope.
Redundant output signal	R1, R2, R3, R4	By using a double potentiometer the sensor delivers two independent output signals. R1: 2 x potentiometer output R2: 2 x voltage output R3: 2 x current output R4: 2 x CANopen
Sensor housing (drawing see <a href="#">page 5</a> )	C1, C2, C3	Standard: open housing and open rope bridge ( <i>Especially suited for applications under the conditions of fine dust and fluids.</i> ) C1: perforated plate covering and open rope bridge ( <i>Especially suited for applications under the conditions of dirt, particle size &gt;2 mm and fluids.</i> ) C2: perforated plate covering and closed rope bridge ( <i>Especially suited for applications under the conditions of dirt, particle size &gt;2 mm and fluids, protection against impact and shock</i> ) C3: closed housing and closed rope bridge ( <i>Especially suited for applications under the conditions of adhesive dust, cement, concrete, clay, protection against impact and shock.</i> )
Wire rope diameter	D05, D10, D15	The wire rope is made of V4A stainless steel, 1.4401. Please choose the wire rope diameter in part two of the order code. D05: Ø 0.5 mm (standard) D10: Ø 1 mm (not with measurement ranges 9 m and 10 m) D15: Ø 1.5 mm (not with measurement ranges 7 m to 10 m)
Rope fixation by M4 thread	M4	Optional, pivoted rope fixation with screw thread M4, length 22 mm. Ideal for attachment to through holes or thread holes M4.
Rope fixation with cylindrical pin and M6 through bore	ZH, ZR	ZH: cylindrical pin with M6 through bore ZR: cylindrical pin with M6 through bore and car-bine ring
Protection class IP69K (only in combination with cable output)	IP69	All relevant components are completely encapsulated. Suitable for close-range high pressure or high temperature spray downs.
Increased see water protection (drawing see <a href="#">page 5</a> )		The components consist of hard-anodized aluminium and V4A connecting elements. This ensures an even higher corrosion resistance, which has been especially designed for offshore use. The spring housing is sealed like the electronics housing and includes protection class IP67/IP69. The option reduces the maximal displacement speed to 1.5 m/s.
Increased temperature range Low	T40	The use of special components allow a working temperature down to -40 °C (up to +85°C).
TEDS connector (in combination with analog and cable output only; more information about <a href="#">TEDS</a> )	TD, TDP, TDPS	TD: Assembling TDP: Assembling + programming TDPS: Assembling + programming + 35 measurement points

## ACCESSORIES

### Teach electronics - Squeezer

Draw wire sensors with the analogue output versions 5VT and 10VT are equipped with teachable, internal electronics, called VT-Electronics. The signals provided by the sensor's potentiometer are digitized by the VT-Electronics. This digital information is first processed by the electronics, then transformed back and given out as an analogue output signal 0 to 5 V or 0 to 10 V.

The digitization offers two possibilities of adjustment, by which the sensor can be configured individually using the Squeezer:

- Teaching of the measurement range. After a successful teaching process, the squeezer can be pulled off the sensor and be replaced by a standard cable or connector.
- Setting an individual switching point. The squeezer allows the setting of an individual switching point open collector. The switching signal is emitted through the multi-functional line MFL.



A detailed description of the functions can be found in the [Squeezer manual](#).

### Deflection pulley - UR2

The rope must be extracted from the sensor vertically. The maximum variation from the vertical is 3°. A deflection pulley allows a change in the direction of the wire rope. Several pulleys may be used. The rope clip must not be guided over the deflection pulley. Suitable for standard wire rope diameter 0.5 mm.

Material foot: anodised aluminium  
 Material rope wheel: POM-C  
 Mounting: by 2 hexagon socket or countersunk screws M6, vertical or horizontal mounting possible. Ball bearings: with special low temperature grease and RS-sealing.  
 Temperature: -40...+80 °C

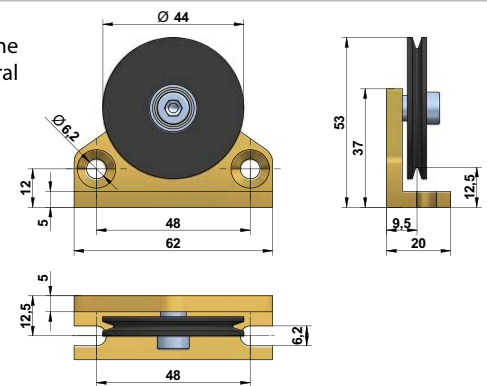
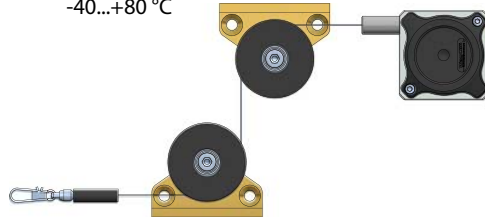

### Rope extension - SV

For bridging a greater distance between the measuring target and the sensor a rope extension can be applied. The rope clip must not be guided over the deflection pulley.

Please specify the length needed in your order (XXXX). The minimum length is 150 mm:

- SV1-XXXX: rope extension (150...4995 mm)
- SV2-XXXX: rope extension (5000...19995 mm)
- SV3-XXXX: rope extension (20000...40000 mm)

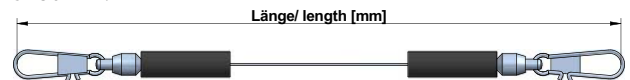

### Magnetic clamp - MGG1

Use the magnetic clamp to quickly attach the rope to metallic objects without any assembly time. A rubber coating provides gentle contact (e. g. on varnished surfaces) and prevents from slipping due to vibration.

The magnet consists of a neodym core for an increased adhesive force of 260 N. The hook makes it easy to attach the rope clip.

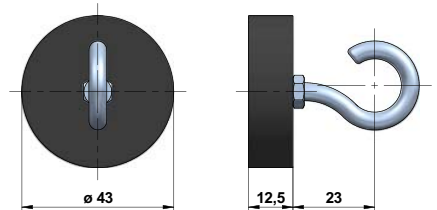

## APPLICATIONS

The draw wire sensors of the mobile hydraulic series MH were specially developed for the demanding area of construction machines and construction equipment. The sensor can be individually configured depending on the application, in which it is used. Small adhesive and abrasive particles with small grain size can easily be removed when using the open MH versions. Seawater resistant protective grating provide a maximum protection against larger foreign objects like tree branches. In case of applications with high safety requirements, thicker stainless-steel wire ropes are available, as well as redundant, analogue outputs. This mobile hydraulics series offers the possibility to perform accurate and cost-effective distance measurement on construction machinery.

**ORDER CODE**

MH120 - □ - □ - □ - □ - □

<b>Measurement range MR [m]</b>	
3 / 4 / 5 / 6 / 7 / 8 / 9 / 10	

<b>Wire rope</b>	
Diameter 0,5 mm (Standard)	D05
Diameter 1 mm (not MR 9...10)	D10
Diameter 1.5 mm (not MR 7...10)	D15

<b>Output signal</b>		
Potentiometer	1 kΩ	1R
Potentiometer	5 kΩ	5R
Potentiometer	10 kΩ	10R
Voltage	0.5...4.5 V	4,5V
Voltage	0...5 V	5V
Voltage	-5...5 V	55V
Voltage	0...10 V	10V
Voltage	0...5 V (teachable)	5VT
Voltage	0...10 V (teachable)	10VT
Current	4...20 mA	420A
Digital	CANopen	WCAN
Digital	CANopen <sup>1)</sup>	WCANP

<b>Connection</b>	
Connector output M12, radial <sup>2)</sup>	SR12
Cable output, radial, 2 m <sup>2)</sup>	KR02
Cable output, radial, 5 m <sup>2)</sup>	KR05
Cable output, radial, 10 m <sup>2), 3)</sup>	KR10

<b>Version</b>	
Standard	-
Sensor with options	O

<sup>1)</sup> offline configurable via Squeezer

<sup>2)</sup> 4 pole in combination with analog outputs  
5 pole in combination with WCAN or option R4  
8 pole in combination with WCANP or options R1, R2, R3

<sup>3)</sup> larger lengths on request

<sup>4)</sup> for more information about TEDS connectors see [here](#)

Option	Description (see <a href="#">page 6</a> )
K1	Cable or connector output to the right
K2	Cable or connector output upwards
K3	Cable or connector output to the left
L10	Improved linearity ±0.1 %
IN	Inverted output signal
R1	Redundant potentiometer output
R2	Redundant voltage output
R3	Redundant current output
R4	Redundant CANopen output
C1	Perforated plate covering + open rope bridge
C2	Perforated plate covering + closed rope bridge
C3	Closed housing + closed rope bridge
M4	rope fixation M4
ZH	Cylindrical pin
ZR	Cylindrical pin with carbine ring
IP69	Protection class IP69K
IAP	Increased sea water protection, IP69K
T40	Temperature range -40...+85 °C
TD	TEDS: assembling <sup>4)</sup>
TDP	TEDS: assembling + programming <sup>4)</sup>
TDPS	TEDS: assembling + programming + 35 measurement points <sup>4)</sup>

Option	Not combinable with
L10	T40
IN	WCAN, WCANP
M4	D15, ZH, ZR
ZH	M4, ZR
ZR	M4, ZH
IP69	SR12, IAP
IAP	SR12, IP69
T40	L10, L25
TD	1R, 5R, 10R, WCAN, WCANP, R1, R2, R3, R4, SR12
TDP	1R, 5R, 10R, WCAN, WCANP, R1, R2, R3, R4, SR12
TDPS	1R, 5R, 10R, WCAN, WCANP, R1, R2, R3, R4, SR12

## GENERAL ACCESSORIES

SQUEEZER2M	accessory for VT or WCANP output, 2 m cable
SQUEEZER5M	accessory for VT or WCANP output, 5 m cable
SQUEEZER10M	accessory for VT or WCANP output, 10 m cable
UR2	deflection pulley (for rope diameter 0.5 mm)

MGG1	magnetic clamp
SV1-XXXX	rope extension (150 mm up to 4995 mm)
SV2-XXXX	rope extension (5000 mm up to 19995 mm)
SV3-XXXX	rope extension (20000 mm up to 40000 mm)

## ACCESSORIES CABLES AND CONNECTORS

### Cable with connector (female) M12, 4 poles, shielded, IP67

K4P2M-S-M12	2 m, straight connector
K4P5M-S-M12	5 m, straight connector
K4P10M-S-M12	10 m, straight connector
K4P2M-SW-M12	2 m, angular connector
K4P5M-SW-M12	5 m, angular connector
K4P10M-SW-M12	10 m, angular connector

### Mating connector (female) M12, 4 poles, for self assembly

D4-G-M12-S	straight connector
D4-W-M12-S	angular connector

### Cable with connector (female) M12, 5 poles, shielded, IP67

K5P2M-S-M12	2 m, straight connector
K5P2M-SW-M12	2 m, angular connector

### Adapter cable WCANP to CAN-Bus (female to male)

K58P03M-SB-M12	0.3 m, shielded, 8 poles to 5 poles
----------------	-------------------------------------

<sup>1)</sup> for analog outputs SVT and 10 VT

<sup>2)</sup> for redundant analog signal and CANopen with offline configuration via Squeezer (WCANP)

### Cable with connector (female) M12, 8 poles, shielded, IP67

K8P2M-S-M12	2 m, straight connector
K8P5M-S-M12	5 m, straight connector
K8P10M-S-M12	10 m, straight connector
K8P2M-SW-M12	2 m, angular connector
K8P5M-SW-M12	5 m, angular connector
K8P10M-SW-M12	10 m, angular connector

### Mating connector (female) M12, 8 poles, for self assembly

D8-G-M12-S	straight connector
D8-W-M12-S	angular connector

### Connection cable sensor to Squeezer (female to male)

K4P1,5M-SB-M12	1.5 m, shielded, 4 poles <sup>1)</sup>
K48P03M-SB-M12	0.3 m, shielded, 8 poles to 4 poles <sup>2)</sup>

## ACCESSORIES DISPLAYS

### Digital displays for sensors with analog output, 2 channel

WAY-AX-S	touch screen, supply: 18...30 VDC
WAY-AX-AC	touch screen, supply: 115...230 VAC

For more information and options please refer to the [WAY-AX data sheet](#).