

DRAW WIRE SENSOR



MH60 SERIES

Key-Features:

- Cost-effective sensor for construction machinery and mobile hydraulics
- Extreme robust construction
- Three housing variations for different environments
- Measurement ranges from 1 to 4 m
- Linearity up to $\pm 0.1\%$ of full scale
- Output signals: potentiometer, current, voltage or CANopen, optional redundant output
- Teachable outputs: 0...5 V, 0...10 V
- Protection class up to IP69K (suitable for steam and high pressure cleaning)
- Temperature range -20...+85 °C (optional -40 °C)
- Optional with TEDS connector

Content

Technical Data	2
Analog Outputs	2
Digital Output CAN _{OPEN}	3
Technical Drawing	3
Options	5
Accessories	6
Applications	6
Order Code	7

DIGITAL OUTPUT CAN_{OPEN}

CAN specification		Full CAN 2.0B (ISO11898)
Communication profile		CANopen CiA 301 V 4.2.0
Device profile		Encoder, absolute linear; CIA 406 V 3.2.0
Error control		Producer Heartbeat, Emergency Message, Node Guarding
Node ID		Default: 7, configurable via SDO and Squeezer (offline configuration) ¹⁾
PDO		1 x TPDO, static mapping
PDO Modes		Event-triggered, Time-triggered, Sync-cyclic, Sync-acyclic
Transmission rate		1 Mbps, 800, 500, 250, 125, 50, 20 kbps configurable via SDO and Squeezer (offline configuration) ¹⁾
Integrated Bus termination resistor		120 Ω, connectible via SDO and Squeezer (offline configuration) ¹⁾
Bus, galvanic separation		No
Supply	[VDC]	8...30
Current consumption		10 mA typical at 24 V, 20 mA typical at 12 V
Measurement rate		1 kHz with 16-bit resolution
Repeatability		
Resolution		0.002 % of measurement range
Electrical protection		inverse polarity protection
Operating temperature	[°C]	-20...+85 / optional: -40...+85
Temperature coefficient	[%/K]	0.0014
EMC		DIN EN61326-1:2013, conformity with directive 2014/30/EU

¹⁾ For more information on the offline configuration please contact us for the CANopen manual.

TECHNICAL DRAWING

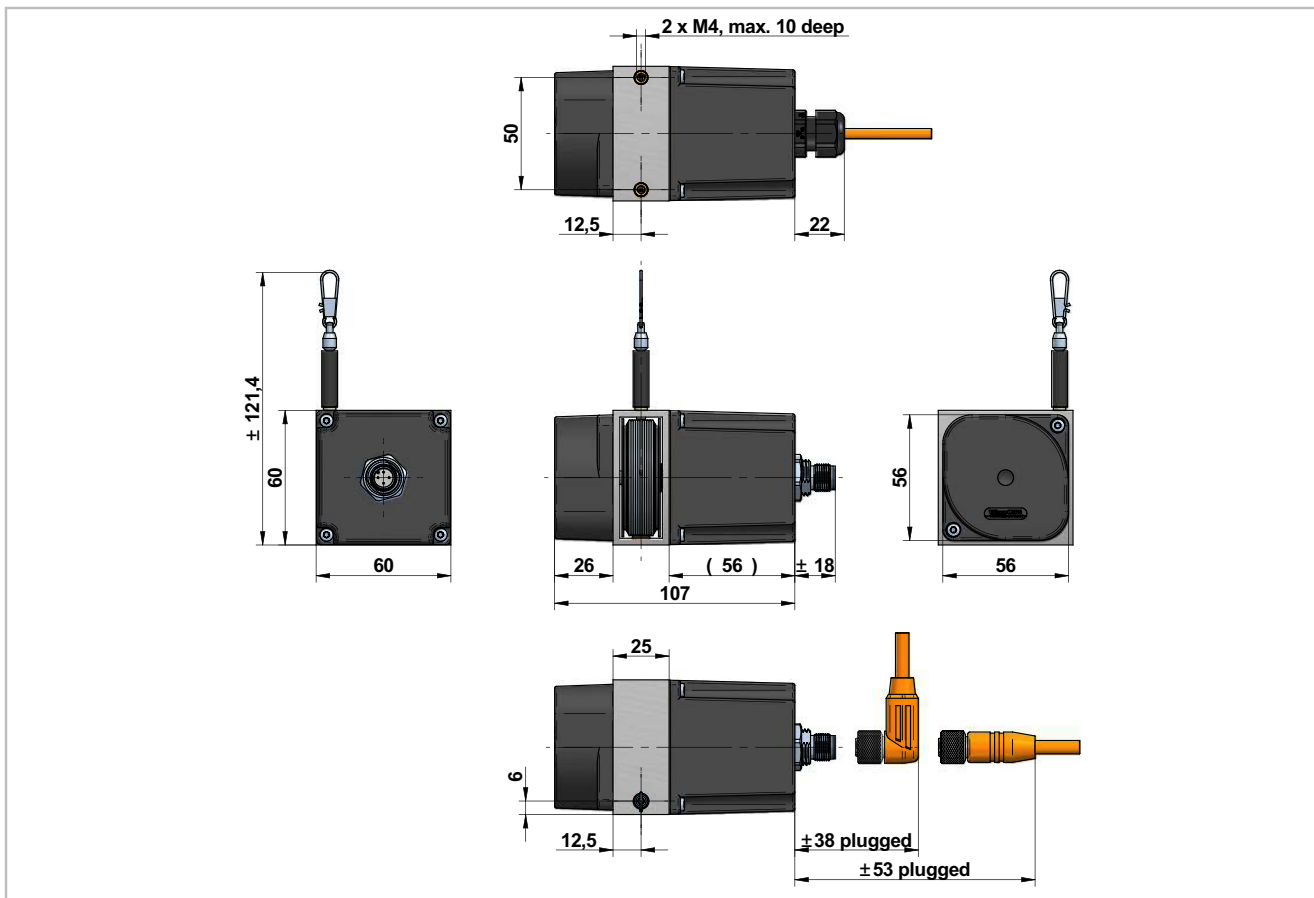

TECHNICAL DRAWING - VARIATIONS

Options L10 and L25: variation with rope tube

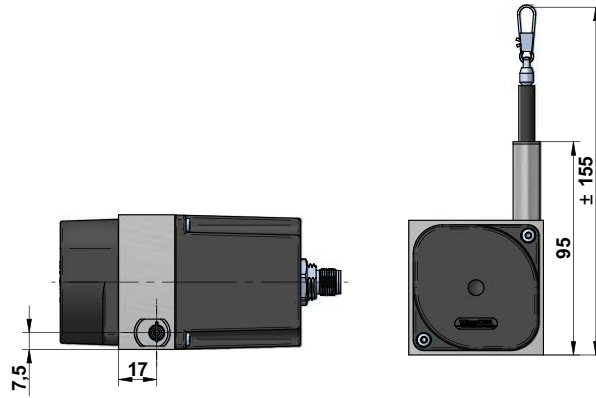

Option C1: housing with perforated plate covering

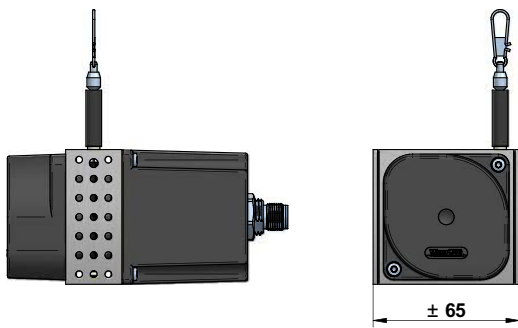

Option C3: closed housing

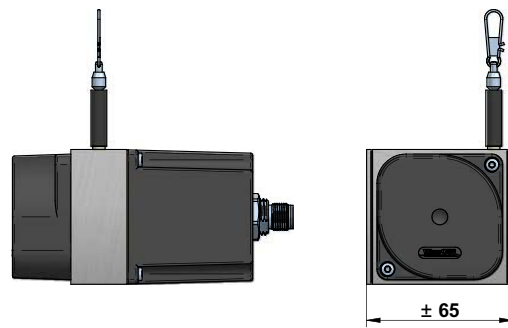

Options S1 and S2: changed rope outlet

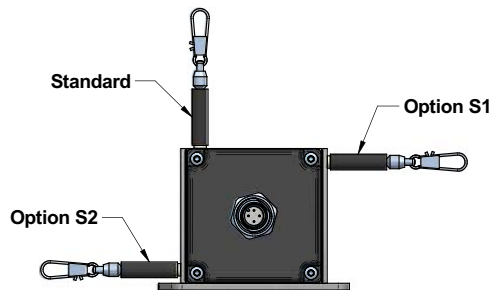

Option BP: variation with base plate

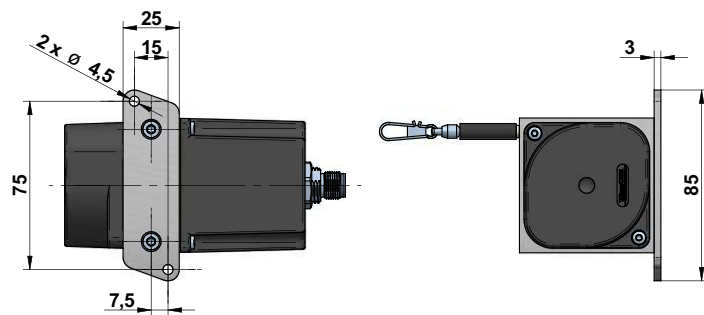

OPTIONS

Option	Order code	Description
Improved linearity (not in combination with S1 or S2; possible combinations see page 2)	L10, L25	Improved linearity 0.1 % (L10) or 0.25 % (L25). Changed technical drawing see page 4 .
Inverted output signal (analog output only)	IN	The analog signal of the sensor is increasing by extracting the rope (standard). Option IN inverts the signal, i.e. the signal of the sensor declines by extracting the rope. <div style="text-align: right;"> </div>
Redundant output signal	R1, R2, R3, R4	By using a double potentiometer the sensor delivers two independent output signals. R1: 2 x potentiometer output R2: 2 x voltage output R3: 2 x current output R4: 2 x CANopen
Changed rope outlet (only in combination with C1 or C3; drawing see page 4)	S1, S2	Standard: rope outlet at the top S1: rope outlet on the right side S2: rope outlet on the left side
Sensor housing (drawing see page 4)	C1, C3	Standard: open housing (<i>Especially suited for applications under the conditions of fine dust and fluids.</i>) C1: housing with perforated plate covering (<i>Especially suited for applications under the conditions of dirt, particle size >2 mm and fluids.</i>) C3: closed housing (<i>Especially suited for applications under the conditions of adhesive dust, cement, concrete, clay, protection against impact and shock.</i>)
Wire rope diameter	D05K, D07K, D10K	The wire rope is made of V4A stainless steel, 1.4401 with a synthetic coating. Please choose the wire rope diameter in part two of the order code. D05K: Ø 0.5 mm (standard) D07K: Ø 0.7 mm D10K: Ø 1 mm (not with measurement ranges 3.5 m and 4 m)
Rope fixation by M4 thread	M4	Optional, pivoted rope fixation with screw thread M4, length 22 mm. Ideal for attachment to through holes or thread holes M4. <div style="text-align: right;"> </div>
Rope fixation with cylindrical pin and M6 through bore through bore	ZH, ZR	ZH: cylindrical pin with M6 through bore ZR: cylindrical pin with M6 through bore and carbine ring <div style="text-align: right;"> </div>
Protection class IP69K (only in combination with cable output)	IP69	All relevant components are completely encapsulated. Suitable for close-range high pressure or high temperature spray downs.
Increased temperature range Low	T40	The use of special components allow a working temperature down to -40 °C (up to +85 °C).
TEDS connector (in combination with analog and cable output only)	TD, TDP, TDPS	TD: Assembling TDP: Assembling + programming TDPS: Assembling + programming + 35 measurement points
Base plate	BP	The MH60 is equipped with a base plate.

ACCESSORIES

Teach electronics - Squeezer

Draw wire sensors with the analogue output versions 5VT and 10VT are equipped with teachable, internal electronics, called VT-Electronics. The signals provided by the sensor's potentiometer are digitized by the VT-Electronics. This digital information is first processed by the electronics, then transformed back and given out as an analogue output signal 0 to 5 V or 0 to 10 V.

The digitization offers two possibilities of adjustment, by which the sensor can be configured individually using the Squeezer:

- Teaching of the measurement range. After a successful teaching process, the squeezer can be pulled off the sensor and be replaced by a standard cable or connector.
- Setting an individual switching point. The squeezer allows the setting of an individual switching point open collector. The switching signal is emitted through the multi-functional line MFL.



A detailed description of the functions can be found in the [Squeezer manual](#).

Deflection pulley - UR2

The rope must be extracted from the sensor vertically. The maximum variation from the vertical is 3°. A deflection pulley allows a change in the direction of the wire rope. Several pulleys may be used. The rope clip must not be guided over the deflection pulley. Suitable for standard wire rope diameter 0.5 mm.

Material foot: anodised aluminium
 Material rope wheel: POM-C
 Mounting: by 2 hexagon socket or countersunk screws M6, vertical or horizontal mounting possible. Ball bearings: with special low temperature grease and RS-sealing.
 Temperature: -40...+80 °C

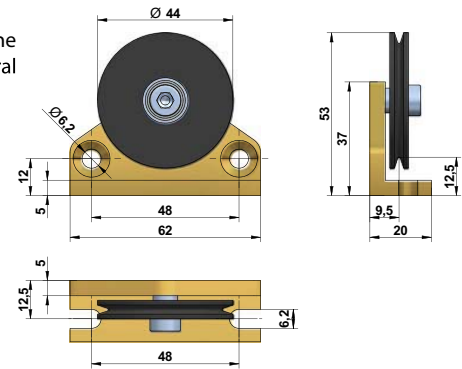
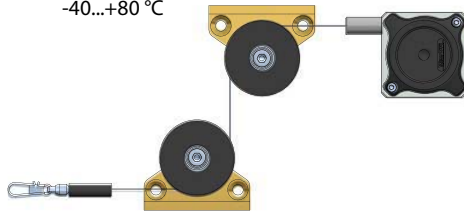

Rope extension - SV

For bridging a greater distance between the measuring target and the sensor a rope extension can be applied. The rope clip must not be guided over the deflection pulley.

Please specify the length needed in your order (XXXX). The minimum length is 150 mm:

- SV1-XXXX: rope extension (150...4995 mm)
- SV2-XXXX: rope extension (5000...19995 mm)
- SV3-XXXX: rope extension (20000...40000 mm)

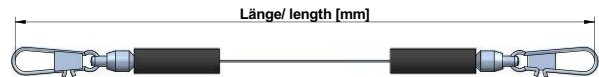

Magnetic clamp - MGG1

Use the magnetic clamp to quickly attach the rope to metallic objects without any assembly time. A rubber coating provides gentle contact (e. g. on varnished surfaces) and prevents from slipping due to vibration. The magnet consists of a neodym core for an increased adhesive force of 260 N. The hook makes it easy to attach the rope clip.

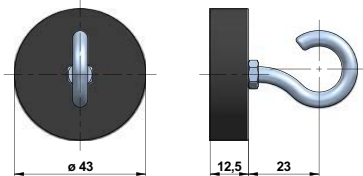

Rope cleaner - RCS (options L10 and L25 only)

Use the RCS rope cleaner to remove dirt from the measuring rope of the sensor. Please note that the maximum measuring range of the sensor is reduced by 29 mm.

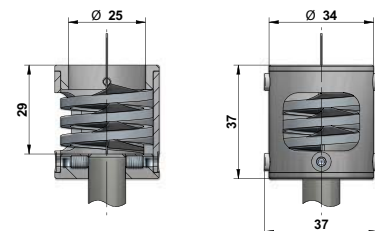

APPLICATIONS

The draw wire sensors of the mobile hydraulic series MH were specially developed for the demanding area of construction machines and construction equipment. The sensor can be individually configured depending on the application, in which it is used. Small adhesive and abrasive particles with small grain size can easily be removed when using the open MH versions. Seawater resistant protective grating provide a maximum protection against larger foreign objects like tree branches. In case of applications with high safety requirements, thicker stainless-steel wire ropes are available, as well as redundant, analogue outputs. This mobile hydraulics series offers the possibility to perform accurate and cost-effective distance measurement on construction machinery.

ORDER CODE

MH60 - □ - □ - □ - □ - □

Measurement range MR [m]	
1 / 1.5 / 2 / 2.5 / 3 / 3.5 / 4	

Wire rope	
Diameter 0.5 mm (Standard)	D05K
Diameter 0.7 mm	D07K
Diameter 1 mm (not MR 3.5...4)	D10K

Output signal		
Potentiometer	1 kΩ	1R
Potentiometer	5 kΩ	5R
Potentiometer	10 kΩ	10R
Voltage	0.5...4.5 V	4,5V
Voltage	0...5 V	5V
Voltage	-5...5 V	55V
Voltage	0...10 V	10V
Voltage	0...5 V (teachable)	5VT
Voltage	0...10 V (teachable)	10VT
Current	4...20 mA	420A
Digital	CANopen	WCAN
Digital	CANopen ¹⁾	WCANP

Connection		
Connector output M12, axial, 4 pole ²⁾	SA12	
Cable output, axial, 2 m ²⁾	KA02	
Cable output, axial, 5 m ²⁾	KA05	
Cable output, axial, 10 m ^{2), 3)}	KA10	

Version		
Standard	-	
Sensor with options	O	

Option	Description (see page 5)
L10	Improved linearity ±0.1 % ⁴⁾
L25	Improved linearity ±0.25 % ⁴⁾
IN	Inverted output signal
R1	Redundant potentiometer output
R2	Redundant voltage output
R3	Redundant current output
R4	Redundant CANopen output
S1	Rope outlet on the right side ⁵⁾
S2	Rope outlet on the left side ⁵⁾
C1	Perforated plate covering
C3	Closed housing
M4	Rope fixation M4
ZH	Cylindrical pin
ZR	Cylindrical pin with carabine ring
IP69	Protection IP69K, only cable output
T40	Temperature range -40...+85 °C
TD	TEDS: assembling ⁶⁾
TDP	TEDS: assembling + programming ⁶⁾
TDPS	TEDS: assembling + programming + 35 measurement points ⁶⁾
BP	Version with base plate

Option	Not combinable with
L10	See page 2, S1, S2, T40
L25	See page 2, S1, S2, T40
IN	WCAN, WCANP
S1	S2, L10, L25
S2	S1, L10, L25
M4	ZH, ZR
ZH	M4, ZR
ZR	M4, ZH
IP69	SA12
T40	L10, L25
TD	1R, 5R, 10R, WCAN, WCANP, R1, R2, R3, R4, SA12
TDP	1R, 5R, 10R, WCAN, WCANP, R1, R2, R3, R4, SA12
TDPS	1R, 5R, 10R, WCAN, WCANP, R1, R2, R3, R4, SA12

¹⁾ offline configurable via Squeezer

²⁾ 4 pole in combination with analog outputs

5 pole in combination with WCAN or option R4

8 pole in combination with WCANP or options R1, R2, R3

³⁾ larger lengths on request

⁴⁾ possible combination for improved linearity see [page 2](#)

⁵⁾ only in combination with C1 or C3

⁶⁾ contact us about TEDS connectors

GENERAL ACCESSORIES

SQUEEZER2M	accessory for VT or WCANP output, 2 m cable
SQUEEZER5M	accessory for VT or WCANP output, 5 m cable
SQUEEZER10M	accessory for VT or WCANP output, 10 m cable
UR2	deflection pulley (for rope diameter 0.5 mm)
MGG1	magnetic clamp

SV1-XXXX	rope extension (150 mm up to 4995 mm)
SV2-XXXX	rope extension (5000 mm up to 19995 mm)
SV3-XXXX	rope extension (20000 mm up to 40000 mm)
RCS-MH60 ¹⁾	rope cleaner (only usable with option L10 or L25)

¹⁾ please note that the maximum measuring range is reduced by 29 mm when using the rope cleaner

ACCESSORIES CABLES AND CONNECTORS

Cable with connector (female) M12, 4 poles, shielded, IP67

K4P2M-S-M12	2 m, straight connector
K4P5M-S-M12	5 m, straight connector
K4P10M-S-M12	10 m, straight connector
K4P2M-SW-M12	2 m, angular connector
K4P5M-SW-M12	5 m, angular connector
K4P10M-SW-M12	10 m, angular connector

Mating connector (female) M12, 4 poles, for self assembly

D4-G-M12-S	straight connector
D4-W-M12-S	angular connector

Cable with connector (female) M12, 5 poles, shielded, IP67

K5P2M-S-M12	2 m, straight connector
K5P2M-SW-M12	2 m, angular connector

Adapter cable WCANP to CAN-Bus (female to male)

K58P03M-SB-M12	0.3 m, shielded, 8 poles to 5 poles
----------------	-------------------------------------

¹⁾ for analog outputs 5VT and 10 VT

²⁾ for redundant analog signal and CANopen with offline configuration via Squeezer (WCANP)

Cable with connector (female) M12, 8 poles, shielded, IP67

K8P2M-S-M12	2 m, straight connector
K8P5M-S-M12	5 m, straight connector
K8P10M-S-M12	10 m, straight connector
K8P2M-SW-M12	2 m, angular connector
K8P5M-SW-M12	5 m, angular connector
K8P10M-SW-M12	10 m, angular connector

Mating connector (female) M12, 8 poles, for self assembly

D8-G-M12-S	straight connector
D8-W-M12-S	angular connector

Connection cable sensor to Squeezer (female to male)

K4P1,5M-SB-M12	1.5 m, shielded, 4 poles ¹⁾
K48P03M-SB-M12	0.3 m, shielded, 8 poles to 4 poles ²⁾

ACCESSORIES DISPLAYS

Digital displays for sensors with analog output, 2 channel

WAY-AX-S	touch screen, supply: 18...30 VDC
WAY-AX-AC	touch screen, supply: 115...230 VAC

Specifications subject to change without prior notice.