

# DRAW WIRE SENSOR



## SX135 SERIES

### Key-Features:

- Measurement ranges 6, 7 or 8 m
- Analog output: potentiometer, voltage, current
- Optional teachable voltage outputs
- Digital Output Incremental: RS422 (TTL), Push-Pull
- Digital Output Absolute: CANopen, SSI, Profibus, EtherCAT, Profinet
- Linearity up to  $\pm 0.02\%$  of full scale
- Protection class up to IP67
- Temperature range:  $-20...+85\text{ }^{\circ}\text{C}$   
(optional  $-40\text{ }^{\circ}\text{C}$  or  $+120\text{ }^{\circ}\text{C}$ )
- High dynamics and interference immunity factor
- Customised versions available
- Optional with TEDS connector

### Content

Technical Data Analog .....	2
Technical Data Incremental .....	3
Technical Data Digital WCAN .....	4
Technical Data Digital Absolute .....	5
Mechanical Data .....	6
Technical Drawing .....	6
Options .....	8
Accessories .....	9
Order Code .....	10



## TECHNICAL DATA ANALOG OUTPUT

Measurement range MR <sup>1)</sup>	[m]	6	7	8
Linearity	[%]		±0.1	
Improved linearity (optional)	[%]		±0.05	
Resolution		see output types below		
Sensor element		Hybrid Potentiometer		
Connection		connector output M12 or cable output axial (TPE cable)		
Protection class		IP65, optional IP67		
Humidity		max. 90 % relative, no condensation		
Temperature		see output types below		
Mechanical data		extraction force, max. velocity and max. acceleration see „ <a href="#">Mechanical Data</a> “		
Housing		aluminium, anodised, spring case PA6		
Draw wire		stainless steel V2A Ø 0.5 mm		
Weight	[g]	approx. 1700, depending on the measurement range		

<sup>1)</sup> others on request

## ELECTRICAL DATA ANALOG OUTPUT

Output type	Potentiometer			Voltage <sup>1)</sup>				Current	Voltage (teachable)	
	1R	5R	10R	4,5V	5V	55V	10V	420A	5VT	10VT
Order Code	1R	5R	10R	4,5V	5V	55V	10V	420A	5VT	10VT
Output	1 kΩ	5 kΩ	10 kΩ	0.5...4.5 V	0...5 V	-5...+5 V	0...10 V	4...20 mA	0...5 V	0...10 V
Supply	max. 30 V			8...30 VDC			12...30 VDC	12...30 VDC <sup>2)</sup>	8...35 VDC	
Recommended cursor current	<1 μA							-		
Current consumption max.	-			max. 25 mA (no load)				-		
Power consumption max.				-				max. 200 mW		
Output current	-			max. 10 mA, min. load 10 kΩ				max. 50 mA in case of error <sup>3)</sup>		max. 10 mA, min. load 1 kΩ
Dynamics	-			<3 ms from 0...100 % and 100...0 %				<1 ms from 0...100 % and 100...0 %		1 ms
Resolution	theoretically unlimited, limited by the noise									1 mV
Noise	depends on the quality of the power supply			0.5 mV <sub>eff</sub>				1.6 μA <sub>eff</sub>		2 mV <sub>eff</sub>
Inverse-polarity protection	-			yes						-
Short-circuit proof	-			yes				-		yes
Operating temperature	-20...+85 °C / optional: -40...+85 °C or -20...+120 °C			-20...+85 °C / optional: -40...+85 °C						
Temperature coefficient	±0.0025 %/K			0.0037 %/K				0.0079 %/K		0.0016 %/K
EMC	-			according to EN 61326-1:2013						

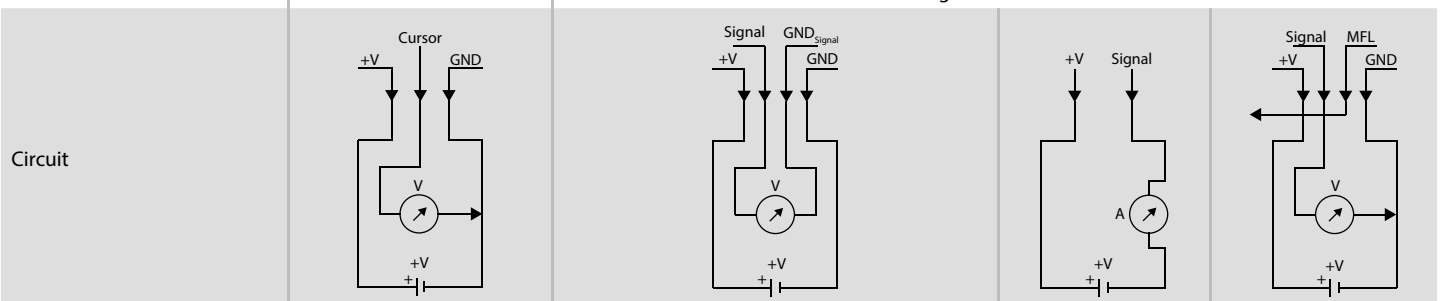

<sup>1)</sup> Galvanically isolated

<sup>2)</sup> Load: 250 Ω (max. 500 Ω)

<sup>3)</sup> Load max. 0.5 kΩ

MFL = multi-functional line

## TECHNICAL DATA DIGITAL OUTPUT INCREMENTAL

Measurement range <sup>1)</sup>	[m]	6	7	8
Linearity	[%]	±0.05		
Improved linearity (optional)	[%]	±0.02 (only in combination with resolution 5.6 pulses/mm, or higher)		
Resolution <sup>1)</sup>	[pulses/mm]	0.28 / 2.8 / 5.6 / 14 (the resolution can be raised by the factor 4 using quadruple edge detection)		
Z-pulse distance	[mm]	357.14		
Sensor element		Incremental-Encoder with optical code disk		
Output signal		A, B and Z pulse (plus inverted pulses /A, /B and /Z)		
Connection		connector output M12 radial or cable output radial (PVC cable)		
Protection class		IP65, optional IP67		
Humidity		max. 90 % relative, no condensation		
Operating temperature	[°C]	-20...+85		
Mechanical data		extraction force, max. velocity and max. acceleration see „ <a href="#">Mechanical Data</a> “		
Housing		aluminium, anodised, spring case PA6		
Draw wire		stainless steel V2A Ø 0.5 mm		
Weight	[g]	approx. 1700, depending on the measurement range		

<sup>1)</sup> others on request

## ELECTRICAL DATA DIGITAL OUTPUT INCREMENTAL

Output type		Line driver L RS422 (TTL compatible)	Push Pull G (HTL)
Supply +V	[VDC]	5 ± 5 %	10...30
Current consumption (no load)	[mA]	max. 90 (typical 40)	max. 100 (typical 50)
Load / channel	[mA]		max. ±20
Pulse frequency	[kHz]		max. 300
Signal level high	[V]	min. 2.5	min. +V - 1
Signal level low	[V]		max. 0.5

Recommended circuit

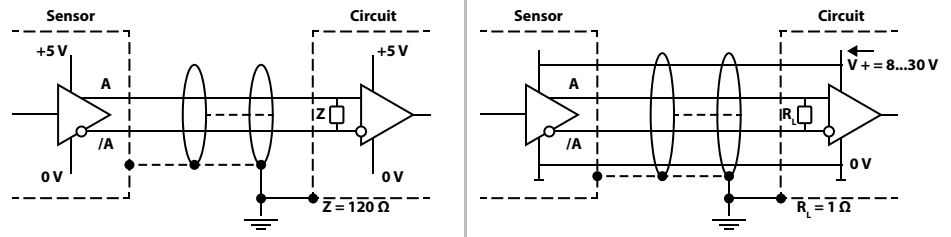

## OUTPUT SIGNAL DIGITAL OUTPUT INCREMENTAL

### Output signal

Pulses A and B are 90° phase-delayed (detection of direction). The Z-Pulse is emitted once per turn. The Z-Pulse distance is 357.14 mm (= circumference of the rope drum) and can be used as a reference mark.

(The diagram shows the signal without inverted signals; time line for return of rope.)

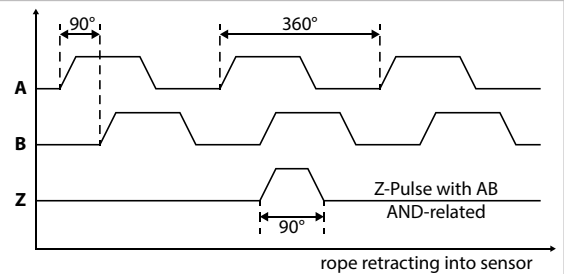

## TECHNICAL DATA DIGITAL OUTPUT ABSOLUTE CAN<sub>OPEN</sub> (WCAN)

Measurement range	[m]	6	7	8
Linearity	[%]	±0.1		
Repeatability	[%]	±0.1		
Resolution		0.002 % of the measurement range		
Sensor element		Potentiometer		
Connection		connector output M12 axial or cable output axial (TPE cable)		
Protection class		IP65, optional IP67		
Humidity		max. 90 % relative, no condensation		
Operating temperature	[°C]	-20...+85 / optional: -40...+85		
Mechanical data		extraction force, max. velocity and max. acceleration see <a href="#">„Mechanical Data“</a>		
Housing		aluminium, anodised, spring case PA6		
Draw wire		stainless steel V2A Ø 0.5 mm		
Weight	[g]	approx. 1700, depending on the measurement range		

## ELECTRICAL DATA DIGITAL OUTPUT ABSOLUTE CAN<sub>OPEN</sub> (WCAN)

Link to the manual		<a href="#">CANopen (WCAN)</a>
CAN specification		Full CAN 2.0B (ISO11898)
Communication profile		CANopen CiA 301 V 4.2.0
Device profile		Encoder, absolute linear; CiA 406 V 3.2.0
Error control		Producer Heartbeat, Emergency Message, Node Guarding
Node ID		Default: 7, configurable via SDO and Squeezer (offline configuration) <sup>1)</sup>
PDO		1 x TPDO, static mapping
PDO Modes		Event-triggered, Time-triggered, Sync-cyclic, Sync-acyclic
Transmission rate		1 Mbps, 800, 500, 250, 125, 50, 20 kbps configurable via SDO and Squeezer (offline configuration) <sup>1)</sup>
Integrated Bus termination resistor		120 Ω, connectible via SDO and Squeezer (offline configuration) <sup>1)</sup>
Bus, galvanic separation		No
Supply	[VDC]	8...30
Current consumption		10 mA typical at 24 V, 20 mA typical at 12 V
Measurement rate		1 kHz with 16-bit resolution
Electrical protection		inverse polarity protection
Temperature coefficient	[%/K]	0.0014
EMC		DIN EN61326-1:2013, conformity with directive 2014/30/EU

<sup>1)</sup> For more information on the offline configuration please refer to the [CANopen manual](#).

## TECHNICAL DATA DIGITAL OUTPUT ABSOLUTE

Type (Link to the encoder data sheet)		<a href="#">SSI</a>	<a href="#">CANopen (CAN)</a>	<a href="#">Profibus-DP</a>	<a href="#">EtherCAT</a>	<a href="#">Profinet</a>
Link to the manual / file		-	<a href="#">Manual / EDS</a>	<a href="#">Manual / GSD</a>	<a href="#">Manual / XML</a>	<a href="#">Manual / GSDMI</a>
Measurement range	[mm]	6 / 7 / 8				
Linearity	[%]	±0.05				
Resolution scalable (via software)		no	yes			
Resolution standard	[pulses/mm] [bit]	22.94 12	22.94 13			
Resolution max.	[pulses/mm] [bit]	- -	183.5 16			
Sensor element		Multiturn-Absolute-Encoder with optical code disk				
Connection		see order code				
Supply	[VDC]	10...30 (reverse polarity protection of the power supply)				
Current consumption (at 24 VDC, no load)	[mA]	max. 50	max. 100	max. 120	max. 200	
Protection class		IP65, optional IP67				
Humidity		max. 90 % relative, no condensation				
Operating temperature	[°C]	-20...+85				
Mechanical data		extraction force, maximum velocity and maximum acceleration see <a href="#">„Mechanical Data“</a>				
Housing		aluminium, anodised, spring case PA6				
Draw wire		stainless steel V2A Ø 0.5 mm				
Weight	[g]	approx. 1700, depending on the measurement range				

## ELECTRICAL DATA DIGITAL OUTPUT ABSOLUTE

### Parameters of the SSI interface (8.5863.122X.G222)

Code	Gray
Output driver	RS485 Transceiver-Type
Permissible load / channel	max. ±20 mA
Signal level	HIGH: typical 3.8 V LOW: with $I_{load} = 20$ mA typical 1.3 V
Resolution	12 bit
SSI clock rate	ST-resolution: 50 kHz...2 MHz
Monoflop time	≤15 µs
Data refresh rate	≤1 µs
Status and Parity bit	on request

### Parameters of the EtherCAT interface (8.5868.12B2.B212)

Code	Binary
Protocol	EtherNet / EtherCAT
Modes	Freerun, Distributed Clock
Diagnostic LED red	LED is ON with the following fault conditions: Sensor error (internal code or LED error), low voltage, over-temperature
Run LED green	LED is ON with the following conditions: Preop-, Safeop and Op-State (EtherCAT Status machine)
2 x Link LEDs yellow	LED is ON with the following conditions (Port IN and Port OUT): Link detected

### Parameters of the Profinet interface (8.5868.12C2.C212)

Code	Binary
Protocol	PROFINET 10
LED Link1/Link2	green = active link / yellow = data transfer
Ezturn Software for Profinet (supplied with the encoder)	<ul style="list-style-type: none"> <li>• Monitoring of cyclic data (e.g. position, speed)</li> <li>• Monitoring of acyclic data (e.g. IMO, electronic name plate, encoder parameters, warnings and error messages, preset)</li> <li>• Setting of preset values</li> <li>• Firmware updates via the bus</li> </ul>

### Parameters of the CANopen interface (CAN) (8.5868.122X.2122)

Code	Binary
Interface	CAN High-Speed acc. to ISO 11898, Basic- and Full-CAN, CAN Specification 2.0 B
Protocol	CANopen profile DS406 V3.2 with manufacturer-specific add-ons
Baud rate	10...1000 kbit/s (can be set via DIP switches or software)
Node address	1...127 (can be set via rotary switches or software)
Termination	can be set via DIP switches or software
SET Button (Option)	Zero or defined value option
LED	LED is ON with the following fault conditions: Sensor error (internal code or LED error) too low voltage, over-temperature

### Parameters of the Profibus DP interface (8.5868.123X.3112)

Code	Binary
Interface	Profibus DP 2.0 Standard (DIN 19245 Part 3), RS485 Driver galvanically isolated
Protocol	Profibus Encoder Profile V1.1 Class1 and Class2 with manufacturer-specific add-ons
Baud rate	maximum 12 Mbit/s
Device address	1...127 (set by rotary switches)
Termination switchable	set by DIP switches
SET Button (Option)	Zero or defined value option
LED	LED is ON with the following fault conditions: Sensor error, Profibus error

## MECHANICAL DATA

Measurement range [m]	Extraction force $F_{min}$ [N]	Extraction force $F_{max}$ [N]	Velocity $V_{max}$ [m/s] <sup>1)</sup>	Acceleration $a_{max}$ [m/s <sup>2</sup> ] <sup>1)</sup>
6	7.8	13.6	10	140
7	8.2	15	10	140
8	8.2	15.2	10	140

<sup>1)</sup> reduced to 80 % with option IP67

## TECHNICAL DRAWING ANALOG OUTPUT AND DIGITAL OUTPUT WCAN

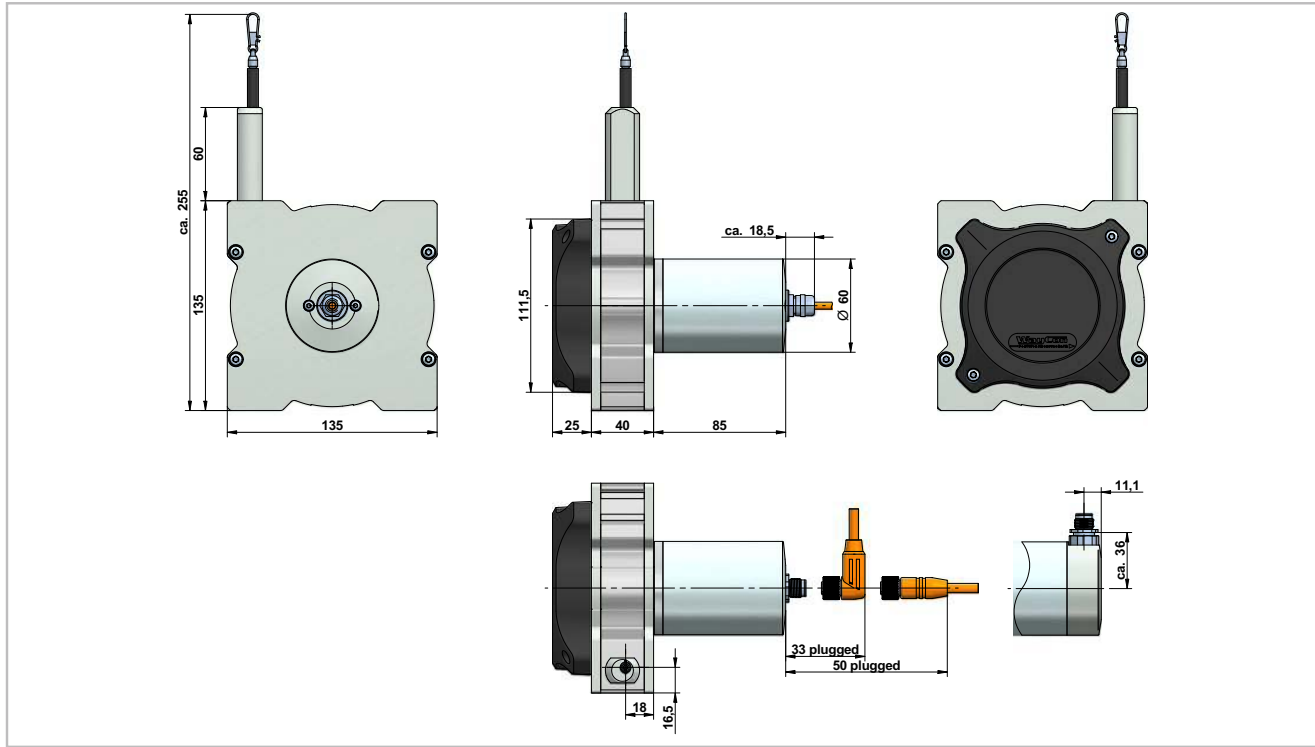

## TECHNICAL DRAWING DIGITAL OUTPUT INCREMENTAL

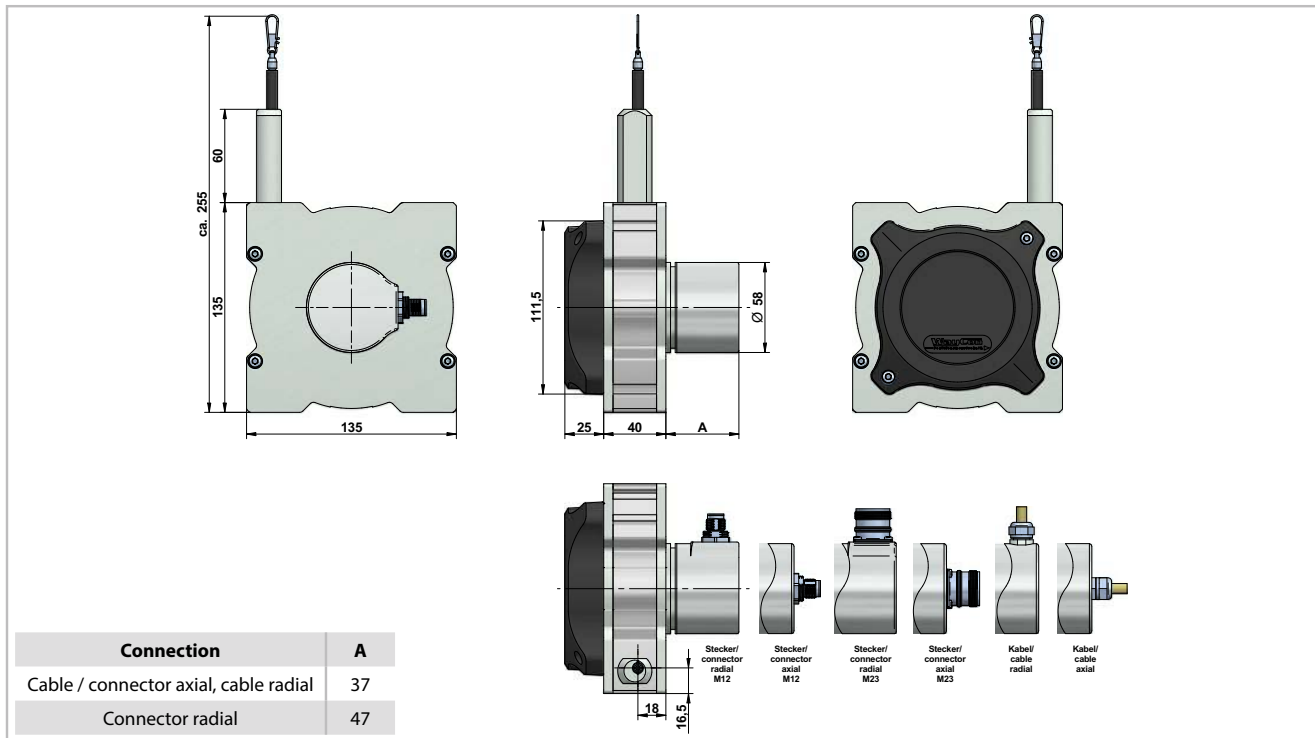

## TECHNICAL DRAWING DIGITAL OUTPUT ABSOLUTE

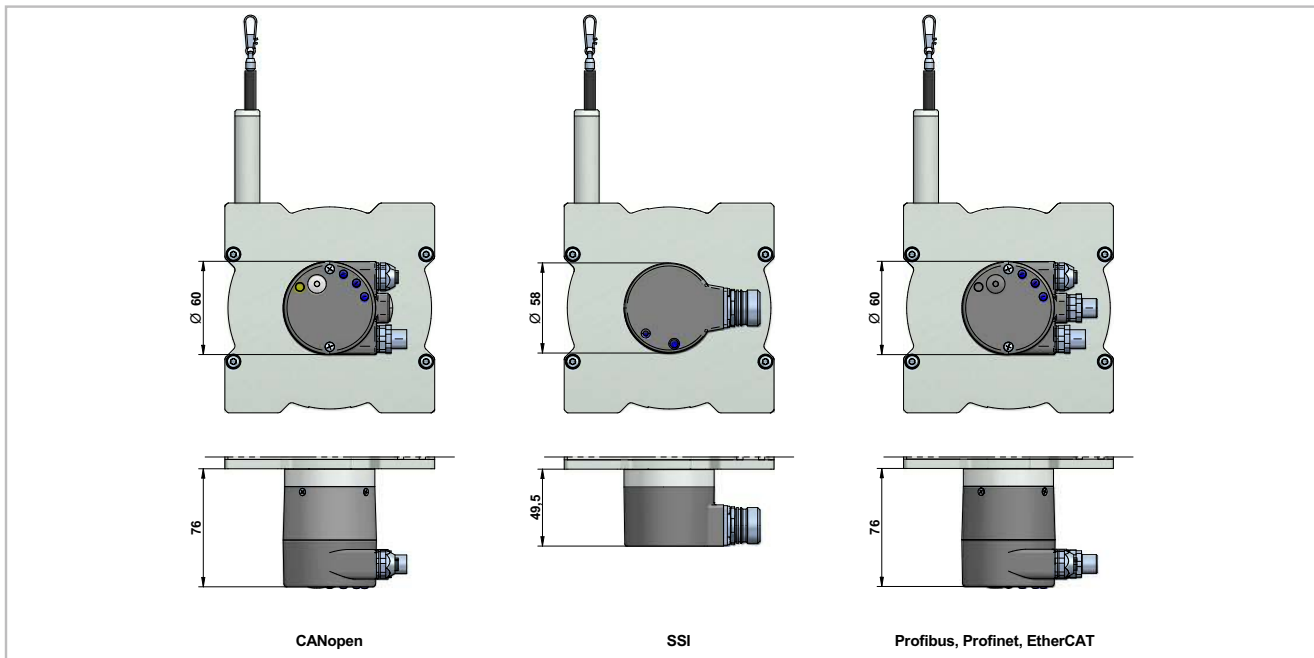

## MOUNTING OPTIONS

### 1. by using the grooves in the sensor housing

The included slot nuts can be easily inserted into the grooves of the sensor housing. The slot nuts have a metric M6 thread.

Two slot nuts are delivered with each sensor.

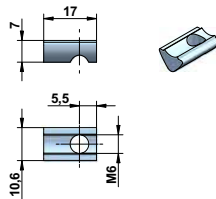

### 2. by angle clamp brackets

The angle clamp brackets feature a bore for M6 screws to fix it on a plate / slab or a profile.

Two brackets are delivered with each sensor.

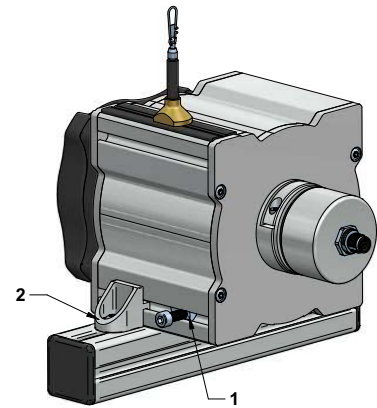
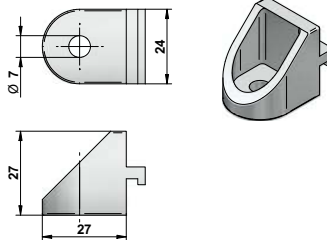

### Note:

The grooves of the sensor housing, the slot nuts and brackets are compatible to the aluminium building kit system from *item Industrietechnik GmbH*.

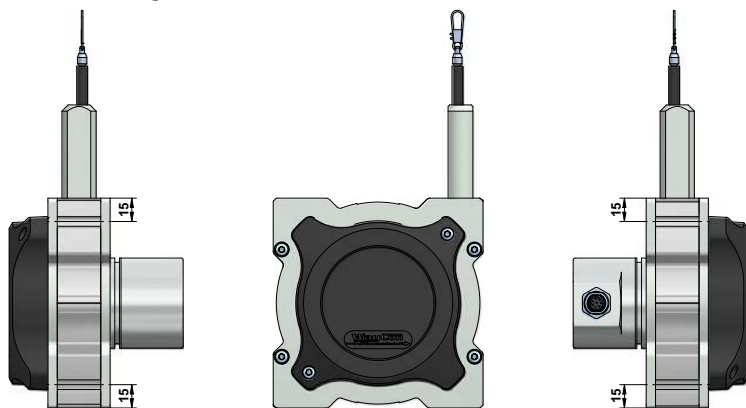

### Position of the grooves

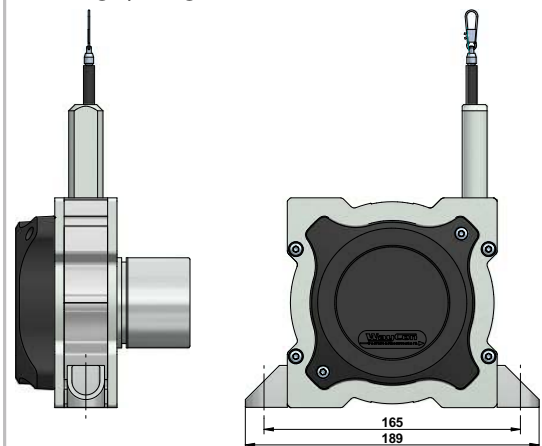

### Mounting by using brackets

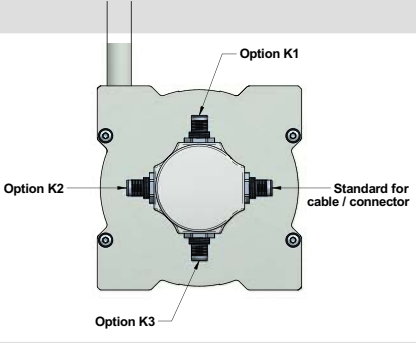
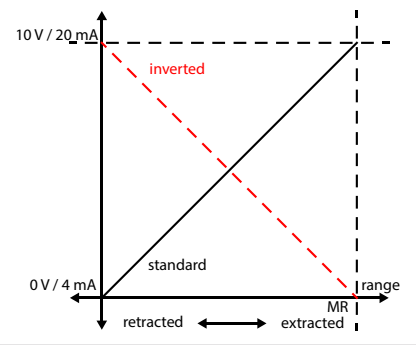
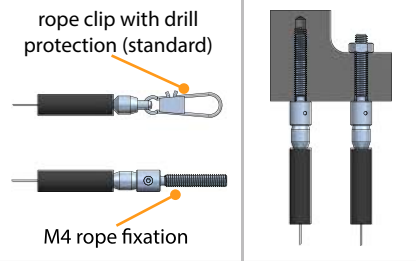

# OPTIONS

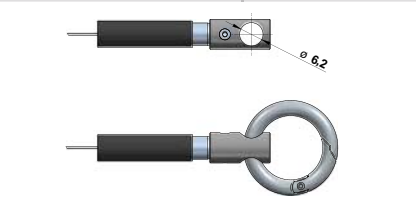
Option	Order code	Description	
Changed cable or connector orientation (NOT with analog output)	K1, K2, K3	Rope outlet points upwards: Standard: sideways, opposite to the rope outlet K1: at the top K2: sideways, same side as the rope outlet K3: at the bottom	
Improved linearity	L02, L05	Improved linearity 0.02 % (L02) or 0.05 % (L05)	
Inverted output signal (analog output only)	IN	The analog signal of the sensor is increasing by extracting the rope (standard). Option IN inverts the signal, i.e. the signal of the sensor declines by extracting the rope.	
Synthetic wire rope	COR	Synthetic wire rope, made out of abrasion resistant and enhanced Coramid.	
Rope fixation by M4 thread	M4	Optional, pivoted rope fixation with screw thread M4, length 22 mm. Ideal for attachment to through holes or thread holes M4.	
Rope fixation by eyelet	RI	The end of the wire rope is equipped with an eyelet instead of a rope clip. Inside diameter 20 mm	
Rope fixation with cylindrical pin and M6 through bore	ZH, ZR	ZH: cylindrical pin with M6 through bore ZR: cylindrical pin with M6 through bore and carbine ring	
Protection class IP67	IP67	Use option IP67, if the sensor will operate in a humid environment. Note that with this option there may occur a light hysteresis in the output signal due to the special sealing. The max. acceleration and displacement speed are reduced to 80 % of the specified value.	
Corrosion protection	CP	Includes a V4A wire rope, stainless steel bearings and option M4. The sensors rope drum gets HARTCOAT® coated. This coating is a hard-anodic oxidation that protects the sensor from corrosion by aggressive media (e. g. sea water) with a hard ceramics-like layer.	
Increased corrosion protection (analog output only)	ICP	Components of the housing and the rope drum get HARTCOAT® coated. Includes the options CP, IP67 and M4.	
Increased temperature range High (potentiometer output only)	H120	Sensors with potentiometer output and cable output can be operated from -20 to +120 °C when this option is used.	
Increased temperature range Low (analog output only)	T40	Special components and a low temperature grease make a working temperature down to -40 °C (up to +85 °C) possible.	
TEDS connector (in combination with analog and cable out-put only; more information about <a href="#">TEDS</a> )	TD, TDP, TDPS	TD: Assembling TDP: Assembling + programming TDPS: Assembling + programming + 35 measurement points	

## Teach electronics - Squeezer

Draw wire sensors with the analogue output versions 5VT and 10VT are equipped with teachable, internal electronics, called VT-Electronics. The signals provided by the sensor's potentiometer are digitized by the VT-Electronics. This digital information is first processed by the electronics, then transformed back and given out as an analogue output signal 0 to 5 V or 0 to 10 V.

The digitization offers two possibilities of adjustment, by which the sensor can be configured individually using the Squeezer:

- Teaching of the measurement range. After a successful teaching process, the squeezer can be pulled off the sensor and be replaced by a standard cable or connector.
- Setting an individual switching point. The squeezer allows the setting of an individual switching point open collector. The switching signal is emitted through the multi-functional line MFL.

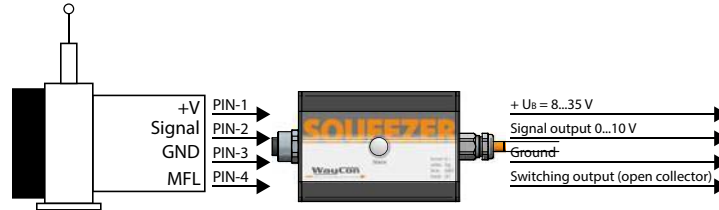

A detailed description of the functions can be found in the [Squeezer manual](#).

## Deflection pulley - UR2

The rope must be extracted from the sensor vertically. The maximum variation from the vertical is 3°. A deflection pulley allows a change in the direction of the wire rope. Several pulleys may be used. The rope clip must not be guided over the deflection pulley. Suitable for standard wire rope diameter 0.5 mm.

Material foot: anodised aluminium  
 Material rope wheel: POM-C  
 Mounting: by 2 hexagon socket or countersunk screws M6, vertical or horizontal mounting possible. Ball bearings: with special low temperature grease and RS-sealing.  
 Temperature: 10...30 °C

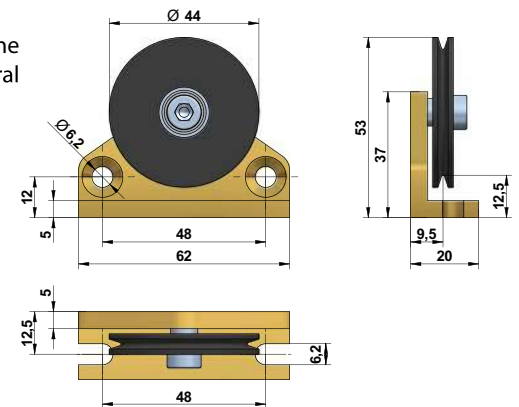
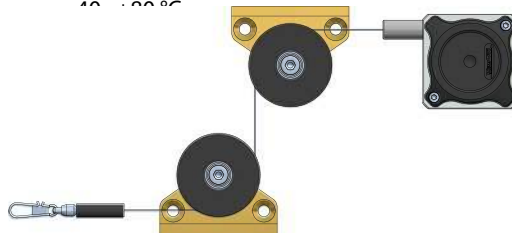

## Rope extension - SV

For bridging a greater distance between the measuring target and the sensor a rope extension can be applied. The rope clip must not be guided over the deflection pulley.

Please specify the length needed in your order (XXXX). The minimum length is 150 mm:

- SV1-XXXX: rope extension (150...4995 mm)
- SV2-XXXX: rope extension (5000...19995 mm)
- SV3-XXXX: rope extension (20000...40000 mm)

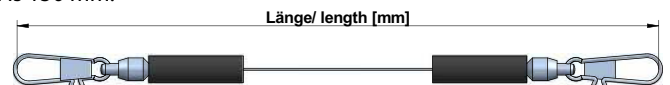

## Magnetic clamp - MGG1

Use the magnetic clamp to quickly attach the rope to metallic objects without any assembly time. A rubber coating provides gentle contact (e. g. on varnished surfaces) and prevents from slipping due to vibration.

The magnet consists of a neodym core for an increased adhesive force of 260 N. The hook makes it easy to attach the rope clip.

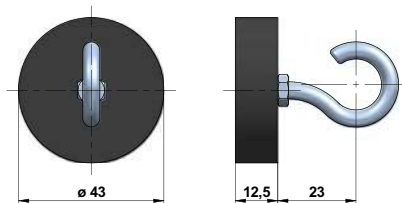

## Rope cleaner - RCS

Use the RCS rope cleaner to remove dirt from the measuring rope of the sensor. Please note that the maximum measuring range of the sensor is reduced by 29 mm and that the RCS is not compatible with the option RI.

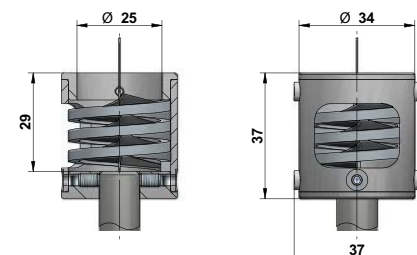

# ORDER CODE ANALOG OUTPUT

SX135 - □ - □ - □ - □

<b>Measurement range MR [m]</b>	
6 / 7 / 8	

<b>Output signal</b>		
Potentiometer	1 kΩ	1R
Potentiometer	5 kΩ	5R
Potentiometer	10 kΩ	10R
Voltage	0.5...4.5 V	4,5V
Voltage	0...5 V	5V
Voltage	-5...+5 V	55V
Voltage	0...10 V	10V
Voltage	0...5 V (teachable)	5VT
Voltage	0...10 V (teachable)	10VT
Current	4...20 mA	420A

<b>Connection</b>	
Connector output M12, axial, 4 poles	<b>SA12</b>
Connector output M12, radial, 4 poles	SR12
Cable output, axial, 2 m, 4 poles	KA02
Cable output, axial, 5 m, 4 poles	KA05
Cable output, axial, 10 m, 4 poles <sup>1)</sup>	KA10

<b>Version</b>	
Standard	-
Sensor with options	O

<sup>1)</sup> larger lengths on request

<sup>2)</sup> for more information about TEDS connectors see [here](#)

**Bold text:** standard with shorter lead time

Option	Description (see <a href="#">page 8</a> )
L05	Improved linearity ±0.05 %
IN	Inverted output signal
COR	Synthetic wire rope (Coramid)
M4	Rope fixation M4
RI	Rope fixation eyelet
ZH	Cylindrical pin
ZR	Cylindrical pin with carbine ring
IP67	Protection class IP67
CP	Corrosion protection
ICP	Increased corrosion protection
H120	Increased temperature range -20...+120 °C
T40	Increased temperature range -40...+85 °C
TD	TEDS: assembling <sup>2)</sup>
TDP	TEDS: assembling + programming <sup>2)</sup>
TDPS	TEDS: assembling + programming + 35 measurement points <sup>2)</sup>

Option	Not combinable with
L05	T40
COR	Measurement range 7/8, H120
M4	CP, ICP
RI	CP, ICP
ZH	CP, ICP
ZR	CP, ICP
IP67	H120, ICP
CP	M4, RI, ZH, ZR, ICP
ICP	M4, RI, ZH, ZR, IP67, CP
H120	4,5V, 5V, 55V, 10V, 5VT, 10VT, 420A, COR, IP67, CP, ICP, T40, TD, TDP, TDPS
T40	L05, H120
TD	1R, 5R, 10R, SA12, SR12, H120, TDP, TDPS
TDP	1R, 5R, 10R, SA12, SR12, H120, TD, TDPS
TDPS	1R, 5R, 10R, SA12, SR12, H120, TD, TDP

## ORDER CODE DIGITAL OUTPUT INCREMENTAL

SX135 - □ - □ - □ - □ - □

<b>Measurement range MR [m]</b> 6 / 7 / 8	
<b>Resolution [Pulses/mm]</b> 0.28 / 2.8 / <b>5.6</b> / 14	
<b>Output signal</b> Line driver RS422 (TTL) Push-Pull (HTL)	<b>L</b> <b>G</b>
<b>Connection</b> Connector output M23, radial, 12 pins Connector output M23, axial, 12 pins Connector output M12, radial, 8 pins Connector output M12, axial, 8 pins Cable output, radial, 2 m <sup>1)</sup> Cable output, radial, 5 m <sup>1)</sup> Cable output, radial, 10 m <sup>1), 2)</sup> Cable output, axial, 2 m <sup>1)</sup> Cable output, axial, 5 m <sup>1)</sup> Cable output, axial, 10 m <sup>1), 2)</sup>	SR23 SA23 <b>SR12</b> SA12 KR02 KR05 KR10 KA02 KA05 KA10
<b>Version</b> Standard Sensor with options	- O

Option	Description (see page 8)
K1	Cable/connector orientation top
K2	Cable/connector orientation left
K3	Cable/connector orientation bottom
L02	Improved linearity ±0.02 %
COR	Synthetic wire rope (Coramid)
M4	Rope fixation M4 thread
RI	Rope fixation eyelet
ZH	Cylindrical pin
ZR	Cylindrical pin with carbine ring
IP67	Protection class IP67
CP	Corrosion protection

Option	Not combinable with
L02	Resolution 0.28/2.8
COR	Measurement range 7/8
M4	CP
RI	CP
ZH	CP
ZR	CP
CP	M4, RI, ZH, ZR

<sup>1)</sup> Line driver: 10 poles / Push-Pull: 8 poles

<sup>2)</sup> larger lengths on request

**Bold text:** standard with shorter lead time

## ORDER CODE DIGITAL OUTPUT ABSOLUTE CAN<sub>OPEN</sub> (WCAN)

SX135 - □ - □ - □ - □

<b>Measurement range MR [m]</b> 6 / 7 / 8	
<b>Output signal</b> CANopen CANopen <sup>1)</sup>	WCAN WCANP
<b>Connection</b> <sup>2)</sup> Connector output M12, axial, 4 poles Cable output, axial, 2 m, 4 poles Cable output, axial, 5 m, 4 poles Cable output, axial, 10 m, 4 poles <sup>3)</sup>	SA12 KA02 KA05 KA10
<b>Version</b> Standard Sensor with options	- O

Option	Description (see page 8)
COR	Synthetic wire rope (Coramid)
M4	Rope fixation M4
RI	Rope fixation eyelet
ZH	Cylindrical pin
ZR	Cylindrical pin with carbine ring
IP67	Protection class IP67
CP	Corrosion protection
ICP	Increased corrosion protection
T40	Increased temperature range -40...+85 °C

Option	Not combinable with
COR	Measurement range 7/8
M4	CP, ICP
RI	CP, ICP
ZH	CP, ICP
ZR	CP, ICP
IP67	ICP
CP	M4, RI, ZH, ZR, ICP
ICP	M4, RI, ZH, ZR, IP67, CP

<sup>1)</sup> offline configurable via Squeezer

<sup>2)</sup> WCAN: 5 poles / WCANP: 8 poles

<sup>3)</sup> larger lengths on request

# ORDER CODE DIGITAL OUTPUT ABSOLUTE

SX135 - [ ] - [ ] - [ ] - [ ]

<b>Measurement range MR [m]</b>	
6 / 7 / 8	

<b>Output signal</b>	
SSI	SSI
CANopen	CAN
Profibus DP	PRO
EtherCAT	CAT
Profinet	NET

<b>Connection</b>	
Connector M12, radial, 8 pins (SSI)	SR12
Connector M23, radial, 12 pins (SSI)	SR23
Cable output, radial, 1 m, PVC (SSI)	KR01
Cable output, radial, 5 m, PVC (SSI)	KR05
Cable gland, radial (CAN, PRO) <sup>1)</sup>	KVBH
Connector 2 x M12, radial, 5 pin (CAN) <sup>1)</sup>	SR12
Connector 3 x M12, radial, 5 pin (PRO) <sup>1)</sup>	SR12
Connector 3 x M12, radial, 4 pin (CAT, NET) <sup>1)</sup>	SR12

<b>Version</b>	
Standard	-
Sensor with options	O

Option	Description (see <a href="#">page 8</a> )
K1	Cable/connector orientation top
K2	Cable/connector orientation left
K3	Cable/connector orientation bottom
COR	Synthetic wire rope (Coramid)
M4	Rope fixation M4 thread
RI	Rope fixation eyelet
ZH	Cylindrical pin
ZR	Cylindrical pin with carbine ring
IP67	Protection class IP67
CP	Corrosion protection

Option	Not combinable with
COR	Measurement range 7/8
M4	CP
RI	CP
ZH	CP
ZR	CP
CP	M4, RI, ZH, ZR

<sup>1)</sup> removable bus terminal cover

## GENERAL ACCESSORIES

SQUEEZER2M	accessory for VT or WCANP output, 2 m cable
SQUEEZER5M	accessory for VT or WCANP output, 5 m cable
SQUEEZER10M	accessory for VT or WCANP output, 10 m cable
UR2	deflection pulley (for rope diameter 0.5 mm)
MGG1	magnetic clamp

SV1-XXXX	rope extension (150 mm up to 4995 mm)
SV2-XXXX	rope extension (5000 mm up to 19995 mm)
SV3-XXXX	rope extension (20000 mm up to 40000 mm)
RCS-SX135-8 <sup>1)</sup>	rope cleaner

<sup>1)</sup> please note that the maximum measuring range is reduced by 29 mm when using the rope cleaner. The RCS is not compatible with the option RI.

## ACCESSORIES ANALOG OUTPUT

### Cable with connector (female) M12, 4 poles, shielded, IP67

K4P2M-S-M12	2 m, straight connector
K4P5M-S-M12	5 m, straight connector
K4P10M-S-M12	10 m, straight connector
K4P2M-SW-M12	2 m, angular connector
K4P5M-SW-M12	5 m, angular connector
K4P10M-SW-M12	10 m, angular connector

### Mating connector (female) M12, 4 poles, for self assembly

D4-G-M12-S	straight connector
D4-W-M12-S	angular connector

### Connection cable sensor to Squeezer (female to male)

K4P1,5M-SB-M12	1.5 m, shielded, 4 poles
----------------	--------------------------

### Digital displays for sensors with analog output, 2 channel

WAY-AX-S	touch screen, supply: 18...30 VDC
WAY-AX-AC	touch screen, supply: 115...230 VAC

For more information and options please refer to the [WAY-AX data sheet](#).

## ACCESSORIES DIGITAL OUTPUT INCREMENTAL

### Cable with connector (female) M12, 8 poles, shielded, IP67

K8P2M-S-M12	2 m, straight connector
K8P5M-S-M12	5 m, straight connector
K8P10M-S-M12	10 m, straight connector
K8P2M-SW-M12	2 m, angular connector
K8P5M-SW-M12	5 m, angular connector
K8P10M-SW-M12	10 m, angular connector

### Cable with connector (female) M23, 12 poles, shielded, IP67

K12P2M-S-M23	2 m, straight connector
K12P5M-S-M23	5 m, straight connector
K12P10M-S-M23	10 m, straight connector

### Mating connector (female) M12, 8 poles, for self assembly

D8-G-M12-S	straight connector
D8-W-M12-S	angular connector

### Mating connector (female) M23, 12 poles, for self assembly

CON012-S	straight connector, metal housing
----------	-----------------------------------

### Digital displays for sensors with HTL output, 2 channel

WAY-DX-S	touch screen, supply: 18...30 VDC
WAY-DX-AC	touch screen, supply: 115...230 VAC

For more information and options please refer to the [WAY-DX data sheet](#).

### Digital displays for sensors with HTL or TTL output, 2 channel

WAY-DXM-S	touch screen, supply: 18...30 VDC
WAY-DXM-AC	touch screen, supply: 115...230 VAC

For more information and options please refer to the [WAY-DXM data sheet](#).

## ACCESSORIES DIGITAL OUTPUT ABSOLUTE CAN<sub>OPEN</sub> (WCAN)

### Cable with connector (female) M12, 5 poles, shielded, IP67

K5P2M-S-M12	2 m, straight connector
K5P2M-SW-M12	2 m, angular connector

### Cable with connector (female) M12, 8 poles, shielded, IP67

K8P2M-S-M12	2 m, straight connector
K8P2M-SW-M12	2 m, angular connector

### Connection cable sensor to Squeezer (female to male)

K48P03M-SB-M12	0.3 m, shielded, 8 poles to 4 poles
----------------	-------------------------------------

### Adapter cable WCANP to CAN-Bus (female to male)

K58P03M-SB-M12	0.3 m, shielded, 8 poles to 5 poles
----------------	-------------------------------------

## ACCESSORIES DIGITAL OUTPUT ABSOLUTE SSI

### Cable with connector (female) M12, 8 poles, shielded, IP67

K8P2M-S-M12	2 m, straight connector
K8P5M-S-M12	5 m, straight connector
K8P10M-S-M12	10 m, straight connector
K8P15M-S-M12	15 m, straight connector

### Mating connector (female) M12, 8 poles, for self assembly

D8-G-M12-S	straight connector
D8-W-M12-S	angular connector

### Digital displays for sensors with SSI output, 2 channel

WAY-SX-S	touch screen, supply: 18...30 VDC
WAY-SX-AC	touch screen, supply: 115...230 VAC

For more information and options please refer to the [WAY-SX data sheet](#).

### Cable with connector (female) M23, 12 poles, shielded, IP67

K12P2M-S-M23	2 m, straight connector
K12P5M-S-M23	5 m, straight connector
K12P10M-S-M23	10 m, straight connector
K12P15M-S-M23	15 m, straight connector

### Mating connector (female) M23, 12 poles, for self assembly

CON012-S	straight connector, metal housing
----------	-----------------------------------

## ACCESSORIES DIGITAL OUTPUT ABSOLUTE CAN<sup>OPEN</sup> (CAN)

### Cable with connector M12, 5 poles, shielded, IP67

K5P2M-B-M12-CAN	2 m, female connector to open ends
K5P2M-SB-M12-CAN	2 m, female connector to male connector
K5P2M-S-M12-CAN	2 m, male connector to open ends

## ACCESSORIES DIGITAL OUTPUT ABSOLUTE PROFIBUS

### Cable with connector M12, 5 poles, shielded, IP67

K5P2M-B-M12-PROF	2 m, female connector to open ends
K5P2M-SB-M12-PROF	2 m, female connector to male connector
K5P2M-S-M12-PROF	2 m, male connector to open ends

### Other

M12-PROF-AW	termination resistor
-------------	----------------------

## ACCESSORIES DIGITAL OUTPUT ABSOLUTE E<sup>THER</sup> CAT AND PROFINET

### Cable with connector (male) M12, 4 poles, shielded, IP67

K4P2M-S-M12-CAT	2 m, straight connector
K4P5M-S-M12-CAT	5 m, straight connector
K4P10M-S-M12-CAT	10 m, straight connector

### Cable with connector M12, 4 poles, shielded, IP67

K4P2M-SS-M12-CAT	2 m, male connector to male connector
K4P5M-SS-M12-CAT	5 m, male connector to male connector
K4P10M-SS-M12-CAT	10 m, male connector to male connector

Please note, that an additional cable is required for the power supply. Appropriate cables can be chosen from the list of the „[Accessories Analog Output](#)“.

**P3 America, Inc.**  
7696 183A, Unit 7B  
Leander TX78641

Phone: (512) 337-7336  
Fax: (858) 225-0439

Subject to change without prior notice.