

DRAW WIRE SENSOR



SX50 SERIES

Key-Features:

- Measurement ranges from 50 to 1250 mm
- Analog output: potentiometer, voltage, current
- Teachable Outputs: 0...5 V, 0...10 V, with an additional Open-Collector switching output
- Digital Output Incremental: RS422 (TTL), Push-Pull
- Digital Output Absolute: CANopen, SSI
- Linearity up to $\pm 0.02\%$ of full scale
- Protection class up to IP67
- Temperature range: $-20...+85\text{ }^{\circ}\text{C}$ (optional $-40\text{ }^{\circ}\text{C}$ or $+120\text{ }^{\circ}\text{C}$)
- High dynamics and interference immunity factor
- Customised versions available
- Optional with TEDS connector

Content

Technical Data Analog	2
Technical Data Incremental	3
Technical Data Digital WCAN	4
Technical Data Digital CAN, SSI	5
Mechanical Data.....	5
Technical Drawing	6
Options	8
Accessories.....	9
Order Code.....	10

TECHNICAL DATA ANALOG OUTPUT

Measurement range MR ¹⁾	[mm]	50	75	100	125	150	225	250	300	375	500	625	750	1000	1250	
Linearity	[%]	±0.5				±0.15						±0.1				
Improved linearity (optional)	[%]	-				±0.1						±0.05				
Improved linearity (optional) ²⁾	[%]	±0.1				-						-				
Resolution		see output types below														
Sensor element		Hybrid Potentiometer														
Connection		connector output M12 axial or cable output axial (TPE cable)														
Protection class		IP65, optional IP67														
Humidity		max. 90 % relative, no condensation														
Temperature		see output types below														
Mechanical data		extraction force, max. velocity and max. acceleration see „Mechanical Data“														
Housing		aluminium, anodised, spring case PA6														
Draw wire		MR 50, 150, 250 mm: stainless steel V2A with synthetic coating Ø 0.6 mm / all others: stainless steel V2A Ø 0.5 mm														
Weight	[g]	300 to 500, depending on the measurement range														

¹⁾ other ranges on request

²⁾ special version with unprotected potentiometer, protection class IP40 (please contact the WayCon sales team)

ELECTRICAL DATA ANALOG OUTPUT

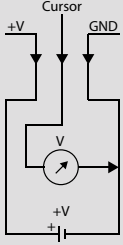
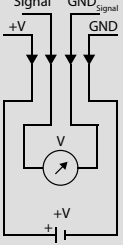
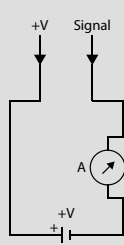
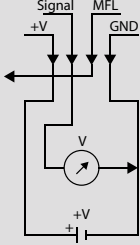
Output type	Potentiometer			Voltage ¹⁾				Current	Voltage (teachable)		
	1R	5R ²⁾	10R ²⁾	4,5V	5V	55V	10V	420A	5VT	10VT	
Order Code	1R	5R ²⁾	10R ²⁾	4,5V	5V	55V	10V	420A	5VT	10VT	
Output	1 kΩ	5 kΩ	10 kΩ	0.5...4.5 V	0...5 V	-5...+5 V	0...10 V	4...20 mA	0...5 V	0...10 V	
Supply	max. 30 V			8...30 VDC			12...30 VDC	12...30 VDC ³⁾	8...35 VDC		
Recommended cursor current	<1 μA							-			
Current consumption max.	-			max. 25 mA (no load)				-			
Power consumption max.				-				max. 200 mW			
Output current	-			max. 10 mA, min. load 10 kΩ				max. 50 mA in case of error ⁴⁾		max. 10 mA, min. load 1 kΩ	
Dynamics	-			<3 ms from 0...100 % and 100...0 %				<1 ms from 0...100 % and 100...0 %		1 ms	
Resolution	theoretically unlimited, limited by the noise									1 mV	
Noise	depends on the quality of the power supply			0.5 mV _{eff}				1.6 μA _{eff}		2 mV _{eff}	
Inverse-polarity protection	-			yes				-		-	
Short-circuit proof	-			yes				-		yes	
Operating temperature	-20...+85 °C / optional: -40...+85 °C or -20...+120 °C			-20...+85 °C / optional: -40...+85 °C							
Temperature coefficient	±0.0025 %/K			0.0037 %/K				0.0079 %/K		0.0016 %/K	
EMC	-			according to EN 61326-1:2013							
Circuit											

¹⁾ Galvanically isolated

²⁾ only for measurement ranges 250 mm or ≥500 mm

³⁾ Load: 250 Ω (max. 500 Ω)

⁴⁾ Load max. 0.5 kΩ

MFL = multi-functional line

TECHNICAL DATA DIGITAL OUTPUT INCREMENTAL

Measurement range ¹⁾	[mm]	500	750	1250
Linearity	[%]	±0.05		
Improved linearity (optional)	[%]	±0.02 (only in combination with resolution 20 pulses/mm, or higher)		
Resolution ¹⁾	[pulses/mm]	1/4 / 10 / 28.8 (the resolution can be raised by the factor 4 using quadruple edge detection)		
Z-pulse distance	[mm]	125		
Sensor element		Incremental-Encoder with optical code disk		
Output signal		A, B and Z pulse (plus inverted pulses /A, /B and /Z)		
Connection		connector output M12 radial or cable output radial (PVC cable)		
Protection class		IP65, optional IP67		
Humidity		max. 90 % relative, no condensation		
Operating temperature	[°C]	-20...+85		
Mechanical data		extraction force, max. velocity and max. acceleration see „Mechanical Data“		
Housing		aluminium, anodised, spring case PA6		
Draw wire		stainless steel V2A Ø 0.5 mm		
Weight	[g]	300 to 500, depending on the measurement range		

¹⁾ others on request

ELECTRICAL DATA DIGITAL OUTPUT INCREMENTAL

Output type		Line driver L RS422 (TTL compatible)	Push Pull G (HTL)
Supply +V	[VDC]	5 ± 5 %	8...30
Current consumption (no load)	[mA]	max. 90 (typical 40)	max. 40
Load / channel	[mA]	max. ±20	
Pulse frequency	[kHz]	max. 300	max. 200
Signal level high	[V]	min. 2.5	min. +V -3
Signal level low	[V]	max. 0.5	

Recommended circuit

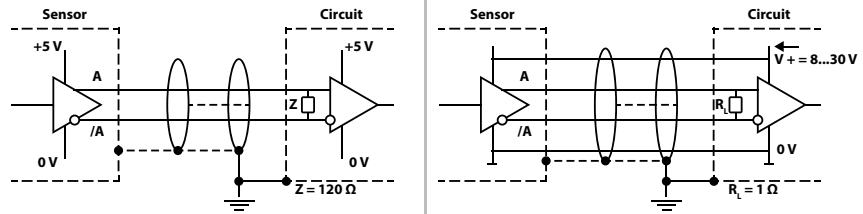

OUTPUT SIGNAL DIGITAL OUTPUT INCREMENTAL

Output signal

Pulses A and B are 90° phase-delayed (detection of direction). The Z-Pulse is emitted once per turn. The Z-Pulse distance is 125 mm (= circumference of the rope drum) and can be used as a reference mark.

(The diagram shows the signal without inverted signals; time line for return of rope.)

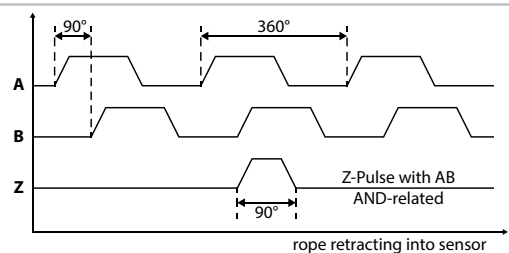

rope retracting into sensor

TECHNICAL DATA DIGITAL OUTPUT ABSOLUTE CAN_{OPEN} (WCAN)

Measurement range	[mm]	50	75	100	125	150	225	250	300	375	500	625	750	1000	1250
Linearity	[%]	±0.5				±0.15						±0.1			
Repeatability	[%]	±0.5				±0.15						±0.1			
Resolution		0.002 % of the measurement range													
Sensor element		Potentiometer													
Connection		connector output M12 axial or cable output axial (TPE cable)													
Protection class		IP65, optional IP67													
Humidity		max. 90 % relative, no condensation													
Operating temperature	[°C]	-20...+85 / optional: -40...+85													
Mechanical data		extraction force, max. velocity and max. acceleration see „Mechanical Data“													
Housing		aluminium, anodised, spring case PA6													
Draw wire		MR 50, 150, 250 mm: stainless steel V2A with synthetic coating Ø 0.6 mm / all others: stainless steel V2A Ø 0.5 mm													
Weight	[g]	300 to 500, depending on the measurement range													

ELECTRICAL DATA DIGITAL OUTPUT ABSOLUTE CAN_{OPEN} (WCAN)

Link to the manual		CANopen (WCAN)
CAN specification		Full CAN 2.0B (ISO11898)
Communication profile		CANopen CiA 301 V 4.2.0
Device profile		Encoder, absolute linear; CiA 406 V 3.2.0
Error control		Producer Heartbeat, Emergency Message, Node Guarding
Node ID		Default: 7, configurable via SDO and Squeezer (offline configuration) ¹⁾
PDO		1 x TPDO, static mapping
PDO Modes		Event-triggered, Time-triggered, Sync-cyclic, Sync-acyclic
Transmission rate		1 Mbps, 800, 500, 250, 125, 50, 20 kbps configurable via SDO and Squeezer (offline configuration) ¹⁾
Integrated Bus termination resistor		120 Ω, connectible via SDO and Squeezer (offline configuration) ¹⁾
Bus, galvanic separation		No
Supply	[VDC]	8...30
Current consumption		10 mA typical at 24 V, 20 mA typical at 12 V
Measurement rate		1 kHz with 16-bit resolution
Electrical protection		inverse polarity protection
Temperature coefficient	[%/K]	0.0014
EMC		DIN EN61326-1:2013, conformity with directive 2014/30/EU

¹⁾ For more information on the offline configuration please refer to the [CANopen manual](#).

TECHNICAL DATA DIGITAL OUTPUT ABSOLUTE

Type (Link to the encoder data sheet)		CANopen (CAN)	SSI
Link to the manual / file		Manual / EDS	-
Measurement range	[mm]	500 / 750 / 1250	
Linearity	[%]	±0.05	
Resolution scalable (via software)		Yes	No
Resolution standard	[pulses/mm]	65.54 (corresponds to 0.015 mm [13 bit])	32.77 (corresponds to 0.03 mm [12 bit])
Resolution max.	[pulses/mm]	524.9 (corresponds to 0.019 mm [16 bit])	-
Sensor element		Multiturn-Absolute-Encoder with optical code disk	
Connection ¹⁾		cable output tangential (PUR cable)	
Supply	[VDC]	10...30 (reverse polarity protection of the power supply)	
Current consumption (at 24 VDC, no load)	[mA]	max. 80	max. 30
Protection class		IP65, optional IP67	
Humidity		max. 90 % relative, no condensation	
Operating temperature	[°C]	-20...+85	
Mechanical data		extraction force, maximum velocity and maximum acceleration see „Mechanical Data“	
Housing		aluminium, anodised, spring case PA6	
Draw wire		stainless steel V2A Ø 0.5 mm	
Weight	[g]	300 to 500, depending on the measurement range	

¹⁾ CANopen only: The sum of all the drop lines should not, for a particular baud rate, exceed the maximum length Lu.

Lu < 5 m cable length for 125 Kbit

Lu < 2 m cable length for 250 Kbit

Lu < 1 m cable length for 1 Mbit

ELECTRICAL DATA DIGITAL OUTPUT ABSOLUTE

Parameters of the CANopen Interface (CAN) (8.F3668.412X.2122)

Code	Binary
Interface	CAN High-Speed acc. to ISO 11898, Basic- and Full-CAN, CAN Specification 2.0 B
Protocol	CANopen profile DS406 V3.2 with manufacturer-specific add-ons LSS-Service DS305 V2.0
Baud rate	10 ... 1000 kbit/s (configurable via software)
Node address	1...127 (configurable via software)
Termination	Configurable via software
LSS Protocol	CIA LSS protocol DS305, Global command support for node address and baud rate, Selective commands via attributes of the identity object

Parameters of the SSI interface (8.F3663.412X.G222)

Code	Gray
Output driver	RS485 Transceiver-Type
Permissible load / channel	max. ±30 mA
Signal level	HIGH: typ. 3.8 V, LOW: with $I_{Load} = 20$ mA typ. 1.3 V
Resolution	12 bit
SSI clock rate	ST-resolution: 50 kHz...2 MHz
Monoflop time	≤15 µs
Data refresh rate	≤1 µs
Status and Parity bit	on request

MECHANICAL DATA

Measurement range [mm]	Extraction force		Speed ¹⁾	Acceleration ¹⁾	Extraction force: Option HG		Acceleration: Option HG
	F_{min} [N]	F_{max} [N]	V_{max} [m/s]	a_{max} [m/s ²]	F_{min} [N]	F_{max} [N]	a_{max} [m/s ²]
50	5.8	6.2	8	200	13.2	13.7	400
75	3.6	3.8	8	200	7.3	7.9	400
100	3.4	3.6	8	200	5.9	6.4	400
125	4.2	4.4	10	300	-		
150	6	6.8	8	200	13.2	13.7	400
225	4.2	4.4	8	200	7.3	8.3	400
250	5	6.4	8	200	13.2	13.7	400
300	2.8	3.2	8	200	5.9	6.7	400
375	4	4.4	10	300	-		
500	3	3.6	8	200	5.9	6.9	400
625	4.4	5.2	10	300	-		
750	3.2	4.4	8	200	7.3	9.8	400
1000	2.8	3.4	8	200	5.9	7.9	400
1250	4.6	5.6	10	300	-		

¹⁾ reduced to 60 % with option IP67

TECHNICAL DRAWING ANALOG OUTPUT AND DIGITAL OUTPUT WCAN

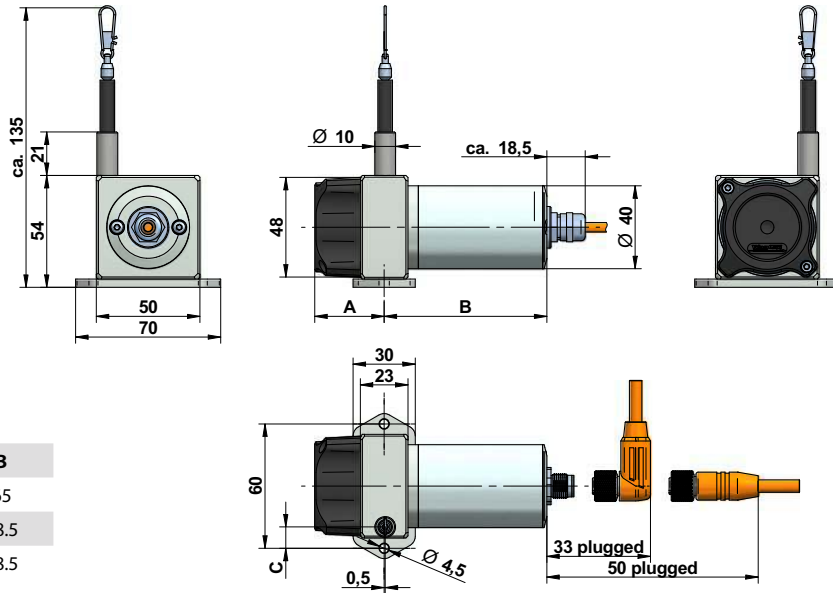

Output	B
Potentiometer	65
Voltage / Current	78.5
WCAN	78.5

Measurement range	Option	A	C
50 / 150 / 250	Standard	26.5	21.3
75 / 225 / 750	Standard	26.5	17
100 / 300 / 500 / 1000	Standard	26.5	12.75
125 / 375 / 625 / 1250	Standard	33.5	10.3
50 / 150 / 250	HG	33.5	21.3
75 / 225 / 750	HG	33.5	17
100 / 300 / 500 / 1000	HG	33.5	12.75

TECHNICAL DRAWING DIGITAL OUTPUT INCREMENTAL

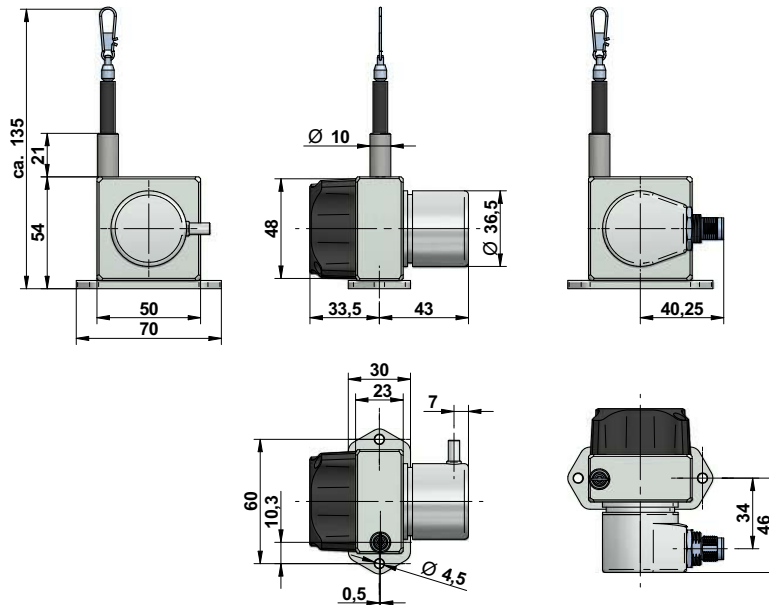

TECHNICAL DRAWING DIGITAL OUTPUT ABSOLUTE

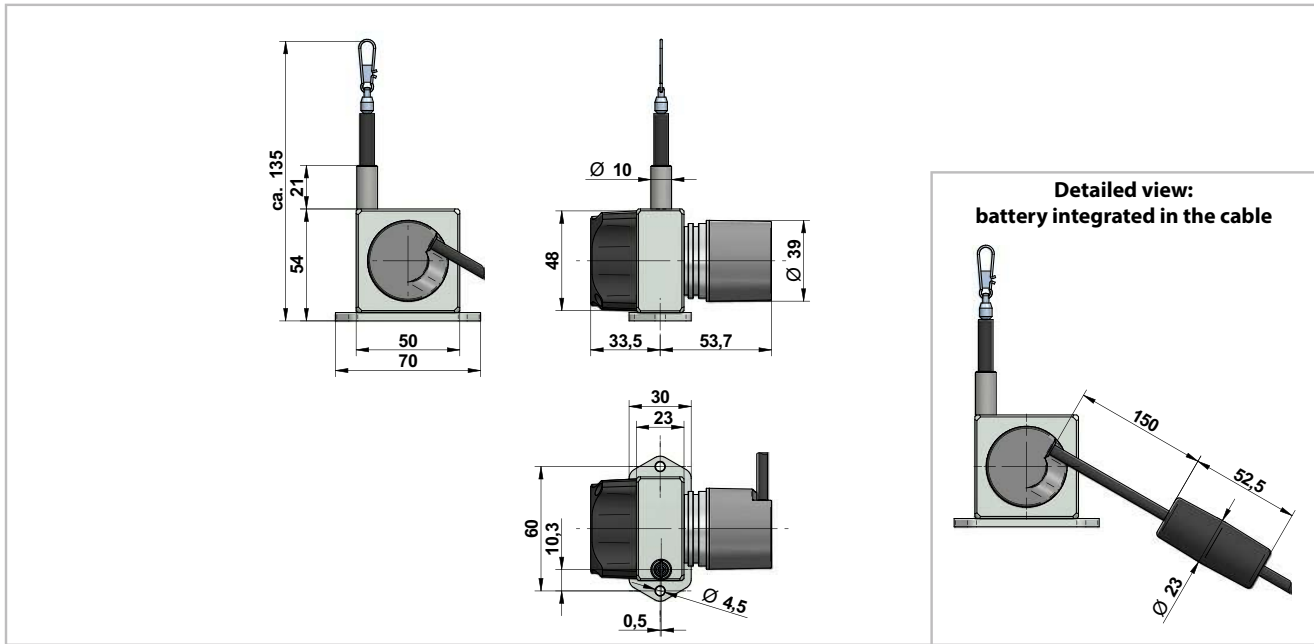

TECHNICAL DRAWING OPTIONS CHANGED ROPE OUTLET AND CABLE OUTPUT

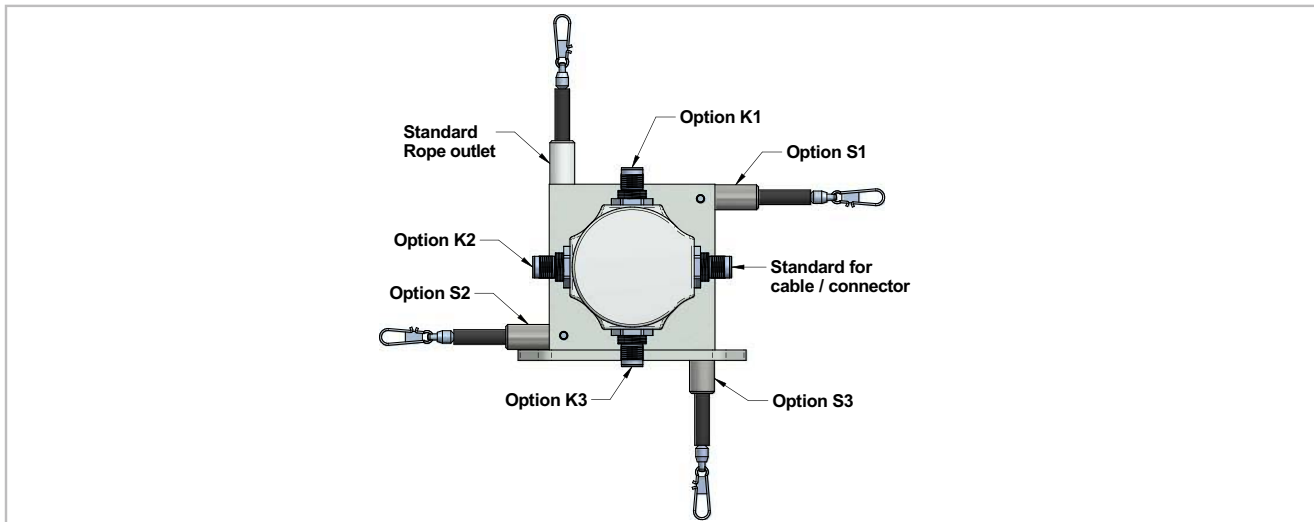

Mounting: standard rope outlet, rope outlet sideways top (S1)
 The sensor is usually installed by using the regular mounting plate (see technical drawing above). By disassembling the mounting plate, there are 4 threads (2 x M3, 2 x M5) in the sensor housing for alternative installation.

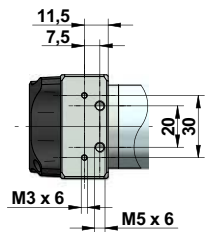

Mounting: rope outlet sideways bottom (S2), rope outlet bottom (S3)
 Sensors with option rope outlet S2 and S3 have a modified base plate:

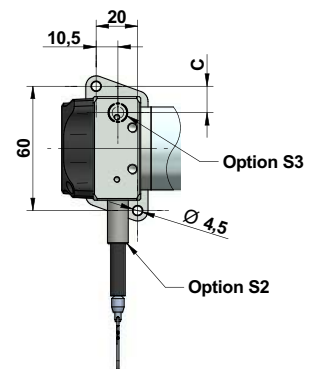

Measurement range	C
50 / 150 / 250	21.3
75 / 225 / 750	17
100 / 300 / 500 / 1000	12.75
125 / 375 / 625 / 1250	10.3

OPTIONS

Option	Order code	Description
Changed cable or connector orientation (NOT with analog output; drawing see page 7)	K1, K2, K3	Rope outlet points upwards: Standard: sideways, opposite to the rope outlet K1: at the top K2: sideways, same side as the rope outlet K3: at the bottom
Improved linearity	L02, L05, L10	Improved linearity 0.02 % (L02), 0.05 % (L05) or 0.1 % (L10)
Inverted output signal (analog output only)	IN	The analog signal of the sensor is increasing by extracting the rope (standard). Option IN inverts the signal, i.e. the signal of the sensor declines by extracting the rope.
Changed rope outlet (see drawing on page 7)	S1, S2, S3	Standard: rope outlet at the top S1: rope outlet sideways at the top S2: rope outlet sideways at the bottom (modified mounting plate, see page 7) S3: rope outlet on the bottom (modified mounting plate, see page 7)
Synthetic wire rope (NOT with MR 50/150/250/750/1000/1250)	COR	Synthetic wire rope, made out of abrasion resistant and enhanced Coramid.
Rope fixation by M4 thread	M4	Optional, pivoted rope fixation with screw thread M4, length 22 mm. Ideal for attachment to through holes or thread holes M4.
Rope fixation by eyelet	RI	The end of the wire rope is equipped with a eyelet instead of a rope clip. Inside diameter 20 mm
Rope fixation with cylindrical pin and M6 through bore	ZH, ZR	ZH: cylindrical pin with M6 through bore ZR: cylindrical pin with M6 through bore and carbine ring
Protection class IP67	IP67	Use option IP67, if the sensor will operate in a humid environment. Note that with this option there may occur a light hysteresis in the output signal due to the special sealing. The max. acceleration and displacement speed are reduced to 60 % of the specified value.
Corrosion protection	CP	Includes a V4A wire rope, stainless steel bearings and option M4. The sensors rope drum gets HARTCOAT® coated. This coating is a hard-anodic oxidation that protects the sensor from corrosion by aggressive media (e. g. sea water) with a hard ceramics-like layer.
Increased corrosion protection (analog output only)	ICP	Components of the housing and the rope drum get HARTCOAT® coated. Includes the options CP, IP67 and M4.
Increased extraction force (analog output only, not for MR 125/375/625/1250)	HG	A reinforced spring drive provides a greater rope tension and allows a higher rope acceleration. Please note the different dimensions of the housing.
Increased temperature range High (potentiometer output only)	H120	Sensors with potentiometer output and cable output can be operated from -20 to +120 °C when this option is used.
Increased temperature range Low (analog output only)	T40	Special components and a low temperature grease make a working temperature down to -40 °C (up to +85 °C) possible.
TEDS connector (in combination with analog and cable output only; more information about TEDS)	TD, TDP, TDPS	TD: Assembling TDP: Assembling + programming TDPS: Assembling + programming + 35 measurement points

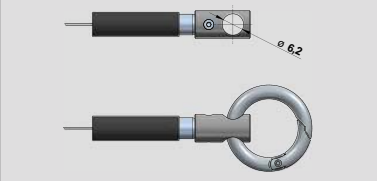
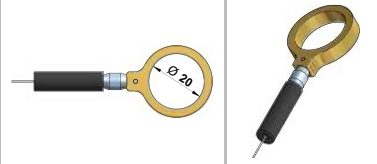
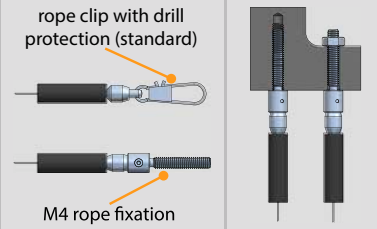
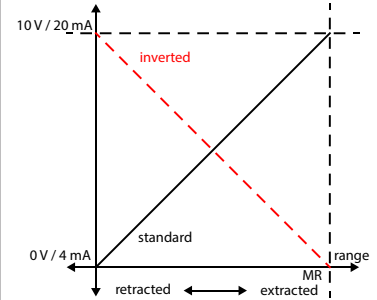

ACCESSORIES

Teach electronics - Squeezer

Draw wire sensors with the analogue output versions 5VT and 10VT are equipped with teachable, internal electronics, called VT-Electronics. The signals provided by the sensor's potentiometer are digitized by the VT-Electronics. This digital information is first processed by the electronics, then transformed back and given out as an analogue output signal 0 to 5 V or 0 to 10 V.

The digitization offers two possibilities of adjustment, by which the sensor can be configured individually using the Squeezer:

- Teaching of the measurement range. After a successful teaching process, the squeezer can be pulled off the sensor and be replaced by a standard cable or connector.
- Setting an individual switching point. The squeezer allows the setting of an individual switching point open collector. The switching signal is emitted through the multi-functional line MFL.



A detailed description of the functions can be found in the [Squeezer manual](#).

Deflection pulley - UR2

The rope must be extracted from the sensor vertically. The maximum variation from the vertical is 3°. A deflection pulley allows a change in the direction of the wire rope. Several pulleys may be used. The rope clip must not be guided over the deflection pulley. Suitable for standard wire rope diameter 0.5 mm.

Material foot: anodised aluminium
 Material rope wheel: POM-C
 Mounting: by 2 hexagon socket or countersunk screws M6, vertical or horizontal mounting possible. Ball bearings: with special low temperature grease and RS-sealing.
 Temperature: 10...200 °C

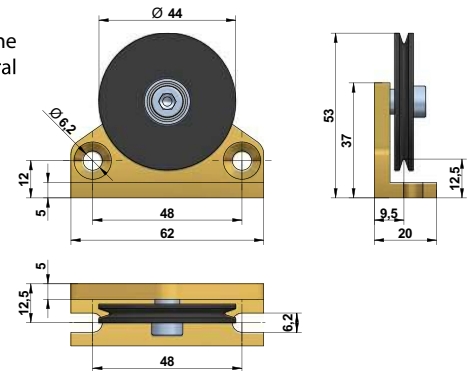
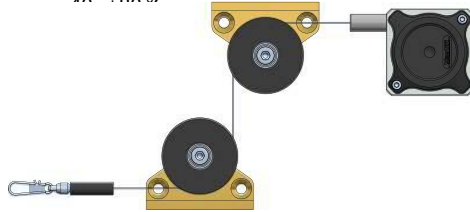

Rope extension - SV

For bridging a greater distance between the measuring target and the sensor a rope extension can be applied. The rope clip must not be guided over the deflection pulley.

Please specify the length needed in your order (XXXX). The minimum length is 150 mm:

- SV1-XXXX: rope extension (150...4995 mm)
- SV2-XXXX: rope extension (5000...19995 mm)
- SV3-XXXX: rope extension (20000...40000 mm)

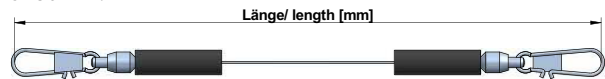

Magnetic clamp - MGG1

Use the magnetic clamp to quickly attach the rope to metallic objects without any assembly time. A rubber coating provides gentle contact (e. g. on varnished surfaces) and prevents from slipping due to vibration.

The magnet consists of a neodym core for an increased adhesive force of 260 N. The hook makes it easy to attach the rope clip.

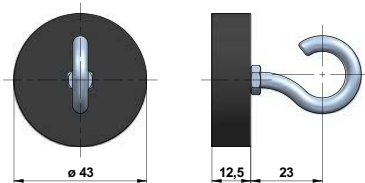

Rope cleaner - RCS

Use the RCS rope cleaner to remove dirt from the measuring rope of the sensor. Please note that the maximum measuring range of the sensor is reduced by 29 mm and that the RCS is not compatible with the option RI.

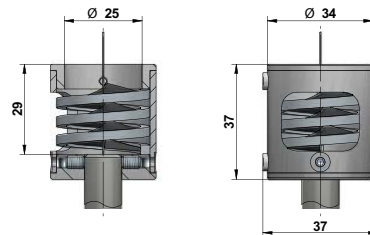

ORDER CODE ANALOG OUTPUT

SX50 - □ - □ - □ - □

Measurement range MR [mm] 50 / 75 / 100 / 125 / 150 / 225 / 250 / 300 / 375 / 500 / 625 / 750 / 1000 / 1250	
--------------------------------------------------------------------------------------------------------------------------	--

Output signal		
Potentiometer	1 kΩ	1R
Potentiometer	5 kΩ ¹⁾	5R
Potentiometer	10 kΩ ¹⁾	10R
Voltage	0.5...4.5 V	4,5V
Voltage	0...5 V	5V
Voltage	-5...+5 V	55V
Voltage	0...10 V	10V
Voltage	0...5 V (teachable)	5VT
Voltage	0...10 V (teachable)	10VT
Current	4...20 mA	420A

Connection	
Connector output M12, axial, 4 poles	SA12
Cable output, axial, 2 m, 4 poles	KA02
Cable output, axial, 5 m, 4 poles	KA05
Cable output, axial, 10 m, 4 poles ²⁾	KA10

Version	
Standard	-
Sensor with options	O

¹⁾ for measurement ranges 250 mm or ≥500 mm only

²⁾ larger lengths on request

³⁾ for more information about TEDS connectors see [here](#)

Bold text: standard with shorter lead time

Option	Description (see page 8)
L05	Improved linearity ±0.05 %
L10	Improved linearity ±0.1 %
IN	Inverted output signal
S1	Rope outlet sideways top
S2	Rope outlet sideways bottom
S3	Rope outlet bottom
COR	Synthetic wire rope (Coramid)
M4	Rope fixation M4
RI	Rope fixation eyelet
ZH	Cylindrical pin
ZR	Cylindrical pin with carbine ring
IP67	Protection class IP67
CP	Corrosion protection
ICP	Increased corrosion protection
HG	Increased extraction force
H120	Increased temperature range -20...+120 °C
T40	Increased temperature range -40...+85 °C
TD	TEDS: assembling ³⁾
TDP	TEDS: assembling + programming ³⁾
TDPS	TEDS: assembling + programming + 35 measurement points ³⁾

Option	Not combinable with
L05	T40
L10	T40
COR	MR 50/150/250/750/1000/1250, H120
M4	CP, ICP
RI	CP, ICP
ZH	CP, ICP
ZR	CP, ICP
IP67	HG, H120, ICP
CP	M4, RI, ZH, ZR, ICP
ICP	M4, RI, ZH, ZR, IP67, CP
HG	MR 125/375/625/1250, IP67
H120	4,5V, 5V, 55V, 10V, 5VT, 10VT, 420A, COR, IP67, CP, ICP, T40, TD, TDP, TDPS
T40	L05, L10, H120
TD	1R, 5R, 10R, SA12, H120, TDP, TDPS
TDP	1R, 5R, 10R, SA12, H120, TD, TDPS
TDPS	1R, 5R, 10R, SA12, H120, TD, TDP

ORDER CODE DIGITAL OUTPUT INCREMENTAL

SX50 - □ - □ - □ - □ - □

Measurement range MR [mm] 500 / 750 / 1250	
Resolution [Pulses/mm] 1 / 4 / 10 / 20 / 28.8	
Output signal Line driver RS422 (TTL) Push-Pull (HTL)	L G
Connection Connector output M12, radial, 4 poles Cable output, radial, 2 m, 4 poles ¹⁾ Cable output, radial, 5 m, 4 poles ¹⁾²⁾	SR12 KR02 KR05
Version Standard Sensor with options	- O

Option	Description (see page 8)
K1	Cable/connector orientation top
K2	Cable/connector orientation left
K3	Cable/connector orientation bottom
L02	Improved linearity ±0.02 %
S1	Rope outlet sideways top
S2	Rope outlet sideways bottom
S3	Rope outlet bottom
COR	Synthetic wire rope (Coramid)
M4	Rope fixation M4 thread
RI	Rope fixation eyelet
ZH	Cylindrical pin
ZR	Cylindrical pin with carbine ring
IP67	Protection class IP67
CP	Corrosion protection

Option	Not combinable with
L02	Resolution 1/4/10
COR	MR 750/1250
M4	CP
RI	CP
ZH	CP
ZR	CP
CP	M4, RI, ZH, ZR

¹⁾ Line driver: 10 poles / Push-Pull: 8 poles

²⁾ larger lengths on request

Bold text: standard with shorter lead time

ORDER CODE DIGITAL OUTPUT ABSOLUTE CAN_{OPEN} (WCAN)

SX50 - □ - □ - □ - □ - □

Measurement range MR [mm] 50 / 75 / 100 / 125 / 150 / 225 / 250 / 300 / 375 / 500 / 625 / 750 / 1000 / 1250	
Output signal CANopen CANopen ¹⁾	WCAN WCANP
Connection ²⁾ Connector output M12, axial, 4 poles Cable output, axial, 2 m, 4 poles Cable output, axial, 5 m, 4 poles Cable output, axial, 10 m, 4 poles ³⁾	SA12 KA02 KA05 KA10
Version Standard Sensor with options	- O

Option	Description (see page 8)
S1	Rope outlet sideways top
S2	Rope outlet sideways bottom
S3	Rope outlet bottom
COR	Synthetic wire rope (Coramid)
M4	Rope fixation M4
RI	Rope fixation eyelet
ZH	Cylindrical pin
ZR	Cylindrical pin with carbine ring
IP67	Protection class IP67
CP	Corrosion protection
ICP	Increased corrosion protection
HG	Increased extraction force
T40	Increased temperature range -40...+85 °C

Option	Not combinable with
COR	MR 50/150/250/750/1000/1250
M4	CP, ICP
RI	CP, ICP
ZH	CP, ICP
ZR	CP, ICP
IP67	HG, ICP
CP	M4, RI, ZH, ZR, ICP
ICP	M4, RI, ZH, ZR, IP67, CP
HG	MR 125/375/625/1250, IP67

¹⁾ offline configurable via Squeezer

²⁾ WCAN: 5 poles / WCANP: 8 poles

³⁾ larger lengths on request

ORDER CODE DIGITAL OUTPUT ABSOLUTE

SX50 - □ - □ - □ - □

Measurement range MR [mm] 500 / 750 / 1250	
Output signal CANopen SSI	CAN SSI
Connection Cable output, tangential, 1 m Cable output, tangential, 5 m Cable output, tangential, 10 m	KT01 KT05 KT10
Version Standard Sensor with options	- O

Option	Description (see page 8)
K1	Cable/connector orientation top
K2	Cable/connector orientation left
K3	Cable/connector orientation bottom
S1	Rope outlet sideways top
S2	Rope outlet sideways bottom
S3	Rope outlet bottom
COR	Synthetic wire rope (Coramid)
M4	Rope fixation M4 thread
RI	Rope fixation eyelet
ZH	Cylindrical pin
ZR	Cylindrical pin with carbine ring
IP67	Protection class IP67
CP	Corrosion protection

Option	Not combinable with
COR	MR 750/1250
M4	CP
RI	CP
ZH	CP
ZR	CP
CP	M4, RI, ZH, ZR

GENERAL ACCESSORIES

SQUEEZER2M	accessory for VT or WCANP output, 2 m cable
SQUEEZER5M	accessory for VT or WCANP output, 5 m cable
SQUEEZER10M	accessory for VT or WCANP output, 10 m cable
UR2	deflection pulley (for rope diameter 0.5 mm)
MGG1	magnetic clamp

SV1-XXXX	rope extension (150 mm up to 4995 mm)
SV2-XXXX	rope extension (5000 mm up to 19995 mm)
SV3-XXXX	rope extension (20000 mm up to 40000 mm)
RCS-SX50 ¹⁾	rope cleaner

¹⁾ please note that the maximum measuring range is reduced by 29 mm when using the rope cleaner. The RCS is not compatible with the option RI.

ACCESSORIES ANALOG OUTPUT

Cable with connector (female) M12, 4 poles, shielded, IP67	
K4P2M-S-M12	2 m, straight connector
K4P5M-S-M12	5 m, straight connector
K4P10M-S-M12	10 m, straight connector
K4P2M-SW-M12	2 m, angular connector
K4P5M-SW-M12	5 m, angular connector
K4P10M-SW-M12	10 m, angular connector

Mating connector (female) M12, 4 poles, for self assembly	
D4-G-M12-S	straight connector
D4-W-M12-S	angular connector

Digital displays for sensors with analog output, 2 channel	
WAY-AX-S	touch screen, supply: 18...30 VDC
WAY-AX-AC	touch screen, supply: 115...230 VAC

Connection cable sensor to Squeezer (female to male)	
K4P1,5M-SB-M12	1.5 m, shielded, 4 poles

For more information and options please refer to the [WAY-AX data sheet](#).

ACCESSORIES DIGITAL OUTPUT INCREMENTAL

Cable with connector (female) M12, 8 poles, shielded, IP67

K8P2M-S-M12	2 m, straight connector
K8P5M-S-M12	5 m, straight connector
K8P10M-S-M12	10 m, straight connector
K8P2M-SW-M12	2 m, angular connector
K8P5M-SW-M12	5 m, angular connector
K8P10M-SW-M12	10 m, angular connector

Mating connector (female) M12, 8 poles, for self assembly

D8-G-M12-S	straight connector
D8-W-M12-S	angular connector

Digital displays for sensors with HTL output, 2 channel

WAY-DX-S	touch screen, supply: 18...30 VDC
WAY-DX-AC	touch screen, supply: 115...230 VAC

For more information and options please refer to the [WAY-DX data sheet](#).

Digital displays for sensors with HTL or TTL output, 2 channel

WAY-DXM-S	touch screen, supply: 18...30 VDC
WAY-DXM-AC	touch screen, supply: 115...230 VAC

For more information and options please refer to the [WAY-DXM data sheet](#).

ACCESSORIES DIGITAL OUTPUT ABSOLUTE CAN^{OPEN} (WCAN)

Cable with connector (female) M12, 5 poles, shielded, IP67

K5P2M-S-M12	2 m, straight connector
K5P2M-SW-M12	2 m, angular connector

Cable with connector (female) M12, 8 poles, shielded, IP67

K8P2M-S-M12	2 m, straight connector
K8P2M-SW-M12	2 m, angular connector

Connection cable sensor to Squeezer (female to male)

K48P03M-SB-M12	0.3 m, shielded, 8 poles to 4 poles
----------------	-------------------------------------

Adapter cable WCANP to CAN-Bus (female to male)

K58P03M-SB-M12	0.3 m, shielded, 8 poles to 5 poles
----------------	-------------------------------------

ACCESSORIES DIGITAL OUTPUT ABSOLUTE SSI

Digital displays for sensors with SSI output, 2 channel

WAY-SX-S	touch screen, supply: 18...30 VDC
WAY-SX-AC	touch screen, supply: 115...230 VAC

For more information and options please refer to the [WAY-SX data sheet](#).