

# DRAW WIRE MECHANICS

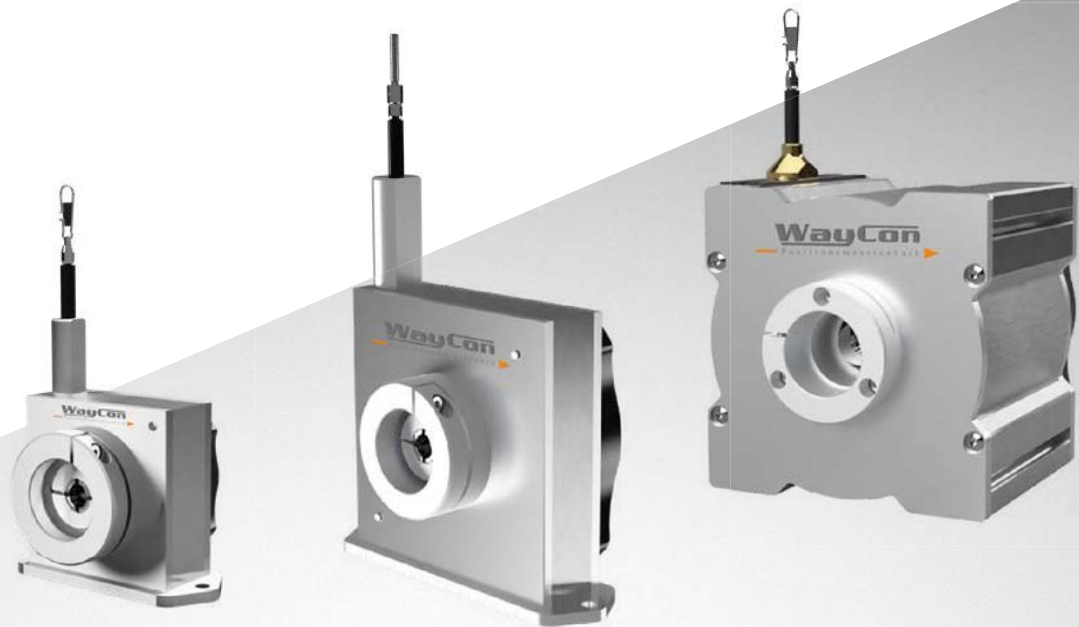

## SX MECHANICS SERIES

### Key-Features:

- Draw wire mechanics for encoder assembly
- Fast and easy encoder mounting
- Measurement ranges from 1 to 42.5 m
- Linearity  $\pm 0.05$  % of full range (with encoder)
- Optional high corrosion protection
- Temperature range -20...+85 °C (optional -40 °C)
- High dynamics
- Customised versions available

### Content

<b>Technical Data</b> .....	<b>2</b>
<b>Technical Drawing</b> .....	<b>3</b>
<b>Options</b> .....	<b>6</b>
<b>Accessories</b> .....	<b>7</b>
<b>Order Code</b> .....	<b>8</b>

## TECHNICAL DATA SX80 MECHANICS

Measurement range	[mm]	1000	1500	2000	2500	3000
Linearity	[%]	±0.05 (with encoder output)				
Sheave circumference	[mm]	200				
Temperature	[°C]	-20...+85 / optional: -40...+85				
Extraction force $F_{min}$	[N]	4.2		5		
Extraction force $F_{max}$	[N]	5.4		6.4		
Velocity $V_{max}$	[m/s]	8				
Acceleration $a_{max}$	[m/s <sup>2</sup> ]	120				
Housing		aluminium, anodised, spring case PA6				
Draw wire		stainless steel V2A Ø 0.5 mm				
Weight	[g]	700 to 900, depending on the measurement range				
Encoder requirements	[mm]	clamping flange diameter: 36, shaft diameter: 10, shaft length: 20				

## TECHNICAL DATA SX120 MECHANICS

Measurement range	[mm]	3000	4000	5000
Linearity	[%]	±0.05 (with encoder output)		
Sheave circumference	[mm]	317.68		
Temperature	[°C]	-20...+85 / optional: -40...+85		
Extraction force $F_{min}$	[N]	8		
Extraction force $F_{max}$	[N]	10	11	11,6
Velocity $V_{max}$	[m/s]	8		
Acceleration $a_{max}$	[m/s <sup>2</sup> ]	120		
Housing		aluminium, anodised, spring case PA6		
Draw wire		stainless steel V2A Ø 0.5 mm		
Weight	[g]	1300 to 1600, depending on the measurement range		
Encoder requirements	[mm]	clamping flange diameter: 36, shaft diameter: 10, shaft length: 20		

## TECHNICAL DATA SX135 MECHANICS

Measurement range	[mm]	6	7	8	10	12	15	20	25	30	35	40	42.5	
Linearity	[%]	±0.05 (with encoder output)												
Sheave circumference	[mm]	357.14					333.33							
Temperature	[°C]	-20...+85 / optional: -40...+85												
Extraction force $F_{min}$	[N]	7.8	8.2		4.8	6.8	6.4	7.8	6.4	7.4	5.4			
Extraction force $F_{max}$	[N]	13.6	15	15.2	7.2	11.2	9.2	11.4	9.6	11.6	9			
Velocity $V_{max}$	[m/s]	8			6			5						
Acceleration $a_{max}$	[m/s <sup>2</sup> ]	120			80			60						
Housing		aluminium, anodised, spring case PA6												
Draw wire		stainless steel V2A Ø 0.5 mm												
Weight	[g]	3200 to 5000, depending on the measurement range												
Encoder requirements	[mm]	clamping flange diameter: 36, shaft diameter: 10, shaft length: 20												

## TECHNICAL DRAWING SX80 MECHANICS

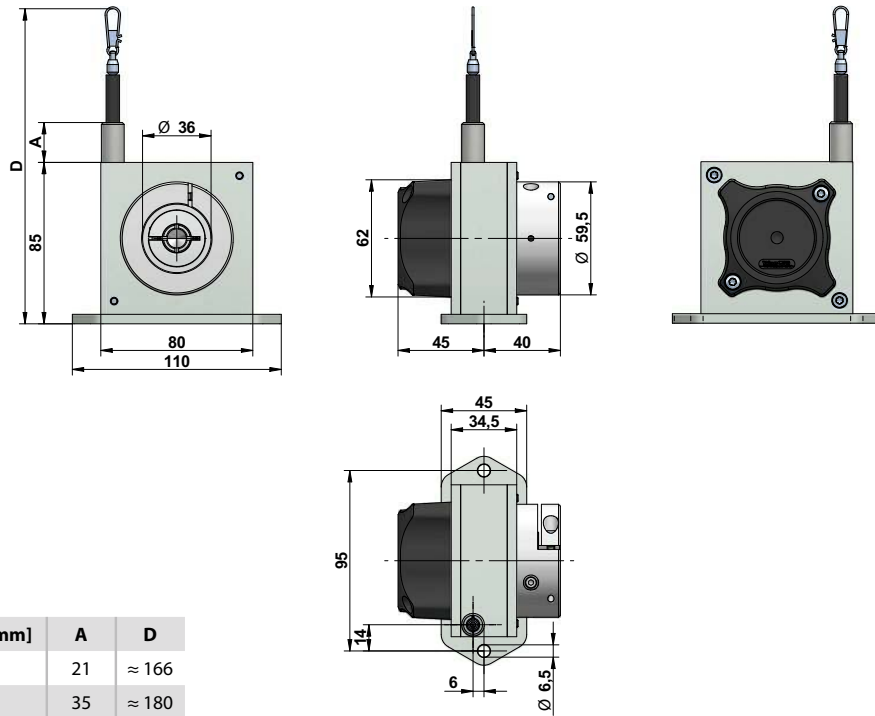

Measurement range [mm]	A	D
1000 / 1500 / 2000	21	≈ 166
2500 / 3000	35	≈ 180

## TECHNICAL DRAWING SX120 MECHANICS

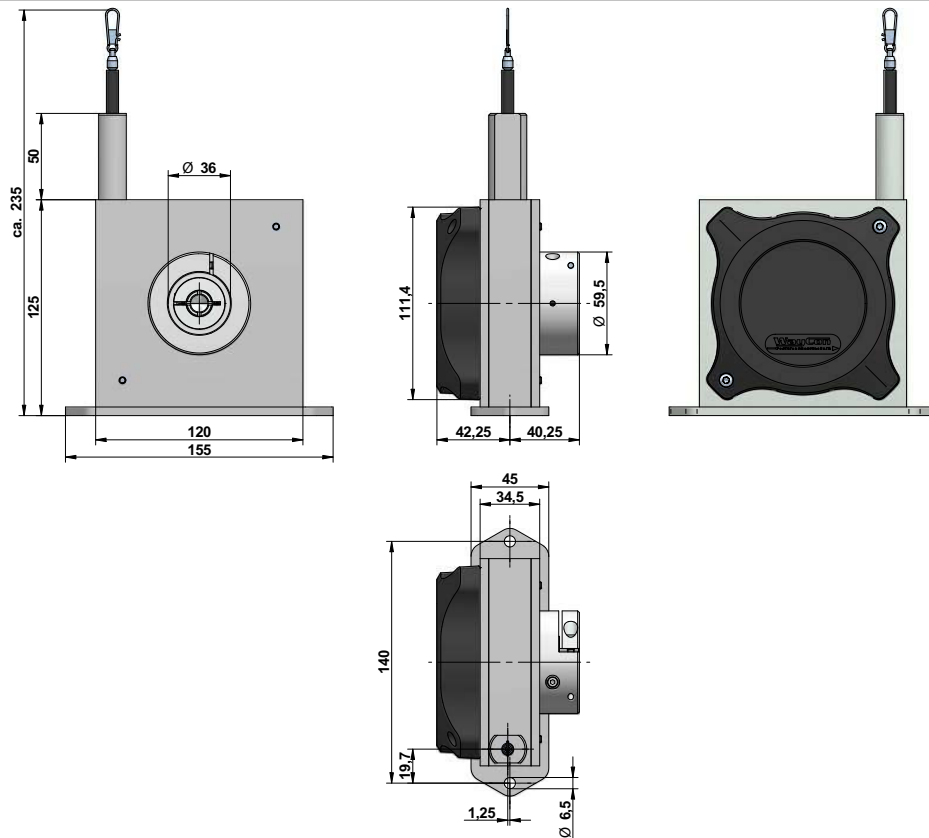



## MOUNTING OPTIONS SX80 AND SX120

### Mounting: standard rope outlet, rope outlet sideways top (S1)

The sensor is usually installed by using the regular mounting plate (see technical drawing above).

By disassembling the mounting plate, there are 2 x M4 threads in the sensor housing for alternative installation.

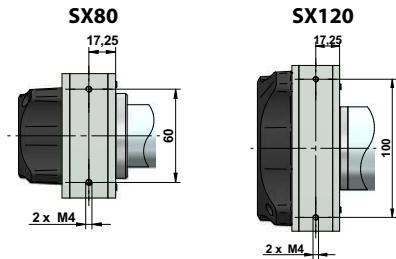

### Mounting: rope outlet sideways bottom (S2), rope outlet bottom (S3)

Sensors with option rope outlet S2 and S3 have a modified base plate:

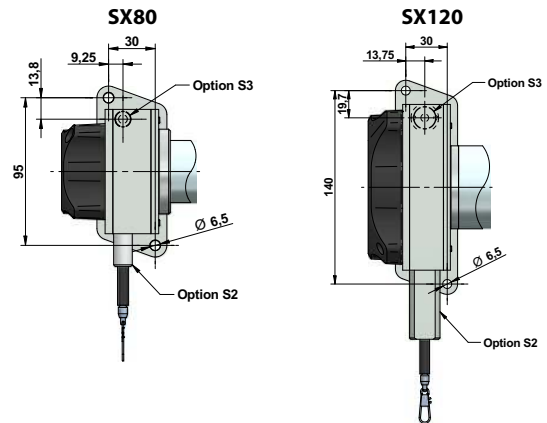

## MOUNTING OPTIONS SX135

### 1. by using the grooves in the sensor housing

The included slot nuts can be easily inserted into the grooves of the sensor housing. The slot nuts have a metric M6 thread.

Each sensor with a measurement range of 20 m or lower is delivered with two slot nuts. Each sensor with a measurement range of 25 m or greater is delivered with four slot nuts.

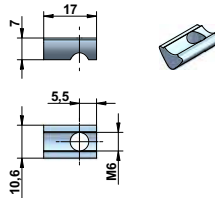

### 2. by angle clamp brackets

The angle clamp brackets feature a bore for M6 screws to fix it on a plate / slab or a profile.

Each sensor with a measurement range of 20 m or lower is delivered with two brackets. Each sensor with a measurement range of 25 m or greater is delivered with four brackets.

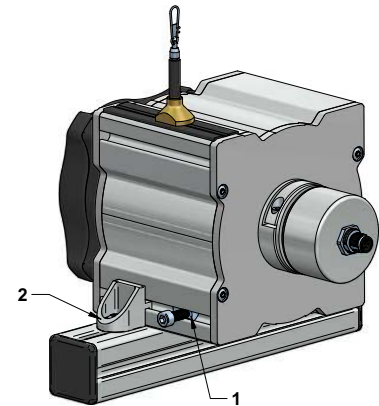
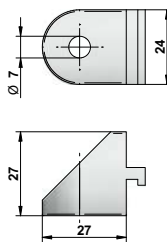

### Note:

The grooves of the sensor housing, the slot nuts and brackets are compatible to the aluminium building kit system from *item Industrietechnik GmbH*.

### Position of the grooves



### Mounting by using brackets

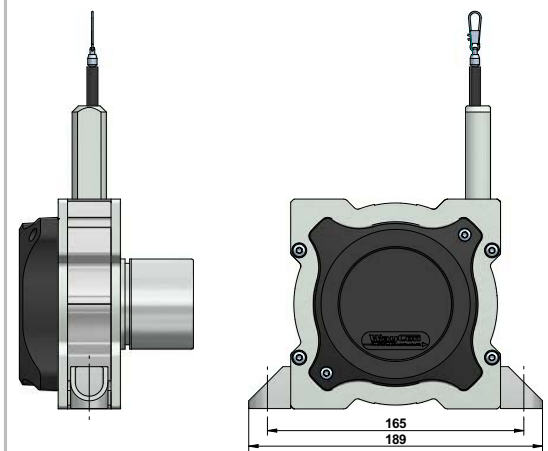

## OPTIONS

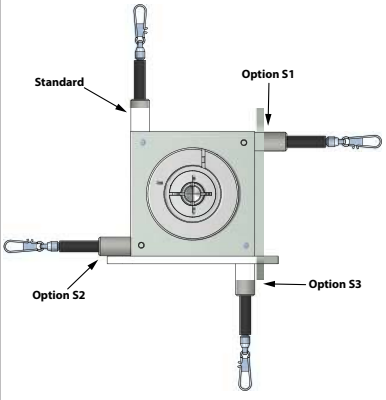
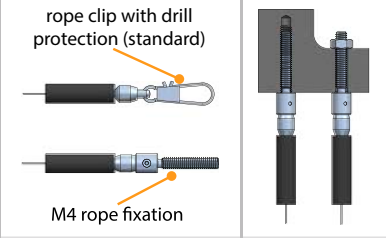
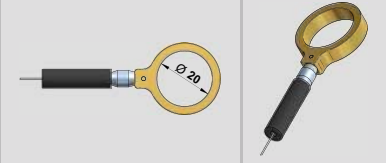
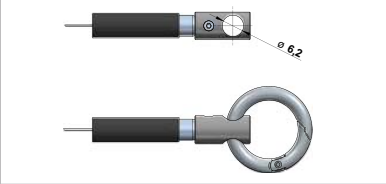
Option	Order code	Description	Description
Changed rope outlet	S1, S2, S3	Standard: rope outlet at the top S1: rope outlet sideways at the top S2: rope outlet sideways at the bottom S3: rope outlet on the bottom	
Synthetic wire rope	COR	Synthetic wire rope, made out of abrasion resistant and enhanced Coramid.	
Rope fixation by M4 thread	M4	Optional, pivoted rope fixation with screw thread M4, length 22 mm. Ideal for attachment to through holes or thread holes M4.	
Rope fixation by eyelet	RI	The end of the wire rope is equipped with a eyelet instead of a rope clip. Inside diameter 20 mm	
Rope fixation with cylindrical pin and M6 through bore	ZH, ZR	ZH: cylindrical pin with M6 through bore ZR: cylindrical pin with M6 through bore and carbine ring	
Corrosion protection	CP	Includes a V4A wire rope, stainless steel bearings and option M4. The sensors rope drum gets HARTCOAT® coated. This coating is a hard-anodic oxidation that protects the sensor from corrosion by aggressive media (e. g. sea water) with a hard ceramics-like layer.	
Increased temperature range low	T40	Special components and a low temperature grease make a working temperature down to -40 °C (up to +85 °C) possible.	

## ACCESSORIES

### Deflection pulley - UR2

The rope must be extracted from the sensor vertically. The maximum variation from the vertical is 3°. A deflection pulley allows a change in the direction of the wire rope. Several pulleys may be used. The rope clip must not be guided over the deflection pulley. Suitable for standard wire rope diameter 0.5 mm.

Material foot: anodised aluminium  
 Material rope wheel: POM-C  
 Mounting: by 2 hexagon socket or countersunk screws M6, vertical or horizontal mounting possible. Ball bearings: with special low temperature grease and RS-sealing.  
 Temperature: -40...+80 °C

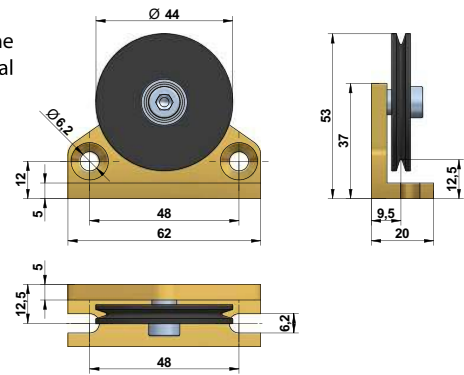
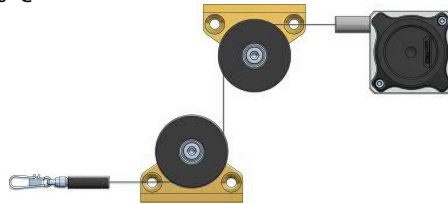

### Rope extension - SV

For bridging a greater distance between the measuring target and the sensor a rope extension can be applied. The rope clip must not be guided over the deflection pulley.

Please specify the length needed in your order (XXXX). The minimum length is 150 mm:

SV1-XXXX: rope extension (150...4995 mm)  
 SV2-XXXX: rope extension (5000...19995 mm)  
 SV3-XXXX: rope extension (20000...40000 mm)

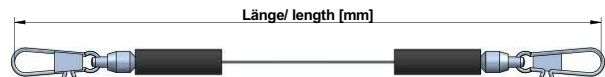

### Magnetic clamp - MGG1

Use the magnetic clamp to quickly attach the rope to metallic objects without any assembly time. A rubber coating provides gentle contact (e. g. on varnished surfaces) and prevents from slipping due to vibration. The magnet consists of a neodym core for an increased adhesive force of 260 N. The hook makes it easy to attach the rope clip.

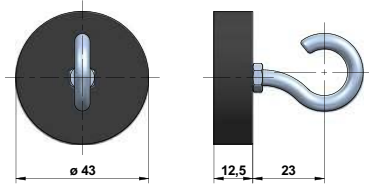

### Rope cleaner - RCS

Use the RCS rope cleaner to remove dirt from the measuring rope of the sensor. Please note that the maximum measuring range of the sensor is reduced by 29 mm and that the RCS is not compatible with the option RI.

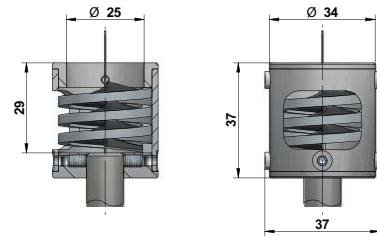

### ORDER CODE SX80 MECHANICS

SX80 -  - F58NK -

<b>Measurement range [mm]</b> 1000 / 1500 / 2000 / 2500 / 3000	<input type="checkbox"/>
---	--------------------------

<b>Version</b> Standard Sensor with options	- O
---	--------

Option	Description
S1	Rope outlet sideways top
S2	Rope outlet sideways bottom
S3	Rope outlet bottom
COR	Synthetic wire rope (Coramid)
M4	Rope fixation M4
RI	Rope fixation eyelet
ZH	Cylindrical pin
ZR	Cylindrical pin with carbine ring
CP	Corrosion protection
T40	Increased temperature -40...+85 °C

Option	Not combinable with
COR	Measurement range 2500 / 3000
M4	CP
RI	CP
ZH	CP
ZR	CP
CP	M4, RI, ZH, ZR

### ORDER CODE SX120 MECHANICS

SX120 -  - F58NK -

<b>Measurement range [mm]</b> 3000 / 4000 / 5000	<input type="checkbox"/>
---	--------------------------

<b>Version</b> Standard Sensor with options	- O
---	--------

Option	Description
S1	Rope outlet sideways top
S2	Rope outlet sideways bottom
S3	Rope outlet bottom
COR	Synthetic wire rope (Coramid)
M4	Rope fixation M4
RI	Rope fixation eyelet
ZH	Cylindrical pin
ZR	Cylindrical pin with carbine ring
CP	Corrosion protection
T40	Increased temperature -40...+85 °C

Option	Not combinable with
M4	CP
RI	CP
ZH	CP
ZR	CP
CP	M4, RI, ZH, ZR

### ORDER CODE SX135 MECHANICS MEASUREMENT RANGE UP TO 8 m

SX135 -  - F58NK -

<b>Measurement range [m]</b> 6 / 7 / 8	<input type="checkbox"/>
---	--------------------------

<b>Version</b> Standard Sensor with options	- O
---	--------

Option	Description
COR	Synthetic wire rope (Coramid)
M4	Rope fixation M4
RI	Rope fixation eyelet
ZH	Cylindrical pin
ZR	Cylindrical pin with carbine ring
CP	Corrosion protection
T40	Increased temperature -40...+85 °C

Option	Not combinable with
COR	Messbereich 7 / 8
M4	CP
RI	CP
ZH	CP
ZR	CP
CP	M4, RI, ZH, ZR

**ORDER CODE SX135 MECHANICS MEASUREMENT RANGE FROM 10 m**

SX135 -  - F58K -

<b>Measurement range [m]</b>	
10 / 12 / 15 / 20 / 25 / 30 / 35 / 40 / 42.5	

<b>Version</b>	
Standard	-
Sensor with options	O

Option	Description
M4	Rope fixation M4
RI	Rope fixation eyelet
ZH	Cylindrical pin
ZR	Cylindrical pin with carbine ring
CP	Corrosion protection
T40	Increased temperature -40...+85 °C

Option	Not combinable with
M4	CP
RI	CP
ZH	CP
ZR	CP
CP	M4, RI, ZH, ZR

**ACCESSORIES**

UR2	deflection pulley (for rope diameter 0.5 mm)
MGG1	magnetic clamp
SV1-XXXX	rope extension (150 mm up to 4995 mm)
SV2-XXXX	rope extension (5000 mm up to 19995 mm)
SV3-XXXX	rope extension (20000 mm up to 40000 mm)

RCS-SX80 <sup>1)</sup>	rope cleaner for SX80 ranges 1000, 1500 and 2000 mm
RCS-SX80-32 <sup>1)</sup>	rope cleaner for SX80 ranges 2500 and 3000 mm
RCS-SX120 <sup>1)</sup>	rope cleaner for SX120
RCS-SX135-8 <sup>1)</sup>	rope cleaner for SX135 range up to 8 m
RCS-SX135 <sup>1)</sup>	rope cleaner for SX135 range 10 m or more

<sup>1)</sup> please note that the maximum measuring range is reduced by 29 mm when using the rope cleaner. The RCS is not compatible with the option RI.