

INSTALLATION GUIDE

Draw wire mechanics SX

FIRST STEPS

This manual will make you familiar with the installation and operation of our draw wire sensors. Please read this manual carefully before initial operation!

Unpacking and checking:

Carefully lift the device out of the box by grabbing the housing. Do not pull the rope. After unpacking the device, check it for any visible damage as a result of rough handling during the shipment. Check the delivery for completeness.

MOUNTING OF THE SENSOR

- Please start by mounting the encoder to the SX draw wire mechanics. A description is given on the following pages.
- Next mount the sensor at the designated place by using the fixing holes before extracting the rope and before attaching the rope to the measuring target.
- Depending on the sensor model it can be installed either by using the boreholes in the mounting plate or by using the supplied T-slot nuts/clamp brackets. You will find a detailed description of both installation methods in this installation guide.
- Open the rope clip after the sensor is fully mounted and carefully extract the measuring rope. Hook the rope clip on the measuring target and close the bracket of the clip. For safety reasons put a screw driver through the clip to extract the rope.

HANDLING THE WIRE ROPE

- When installing or operating the sensor, take care not to let the rope snap back by mistake or extract the rope over the specified measurement range, as this might destroy the sensor.
- The rope must be extracted from the sensor vertically. The maximum variation from the vertical is 3°. Avoid extracting the rope at an inclination, since the durability of the instrument would shorten considerably. If it is not possible to keep the limit of 3°, a deflection pulley has to be used.
- Guide the rope preferably in corners or guarded in channels to prevent pollution or accidental touch.
- Avoid guiding the rope over edges or corners. Use a deflection pulley instead.
- Do not operate the sensor if the rope is buckled or damaged. A ripping of the rope may lead to injuries or a damaging of the sensor.



MOUNTING AN ENCODER

Mounting an encoder to draw wire mechanics SX80, SX120 and SX135 up to 8 m

The F58NK draw wire mechanics allows a fast and easy encoder assembly by the customer. A detailed description of the mounting procedure is shown in the following pictures.

IMPORTANT: All incremental and absolute encoders are suitable that have a clamping flange with 36 mm diameter, a shaft diameter of 10 mm and a shaft length between 10 and 20 mm.

Mounting by clamping flange

1. Start by inserting the encoder into the clamping flange.



2. The encoder is now connected to the clamping flange.



MOUNTING AN ENCODER

Mounting by clamping flange

3. By tightening (approx. 2 Nm) the inner radial screw with a hexagon screwdriver, size 2.5 the encoder shaft will be clamped to the sensor mechanics and is secured from twisting.



4. By tightening (approx. 2 Nm) the outer radial screw with a hexagon screwdriver, size 2.5 the encoder housing will be clamped to the sensor housing and is secured from twisting. The system is now ready to be mounted at the designated place.



MOUNTING AN ENCODER

Mounting an encoder to draw wire mechanics SX135 with measurement range 10 m and above

The SX135 with measurement ranges 10 m or greater is available in a version (F58K) prepared for an encoder assembly by the customer.

You will find a detailed 3 step description of this EASY-Clamp-Mechanism in the next section.

IMPORTANT: All incremental and absolute encoders are suitable that have a clamping flange with 36 mm diameter, a shaft diameter of 10 mm and a shaft length between 10 and 20 mm.

Easy-Clamp-Mechanism

1. Start by sliding the included coupling (1) onto the shaft of the encoder and fix the set screw (1 Nm) with a hexagon screwdriver, size 2. Please pay attention that the dimension between contact surface of the encoder and the end of the cylinder bolt is 35 mm.

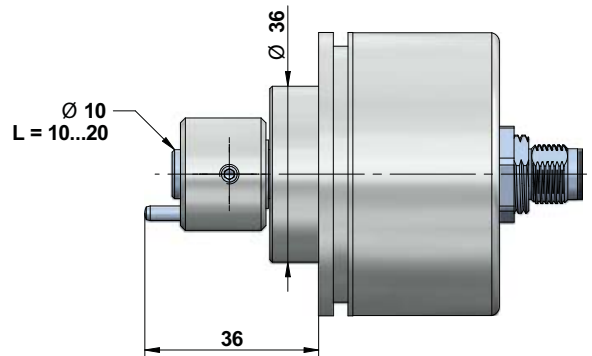
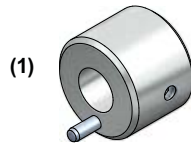

2. The next step is to mount the encoder into the easy-clamp-flange. The cylinder bolt (1) of the coupling must slip into the spring (2).

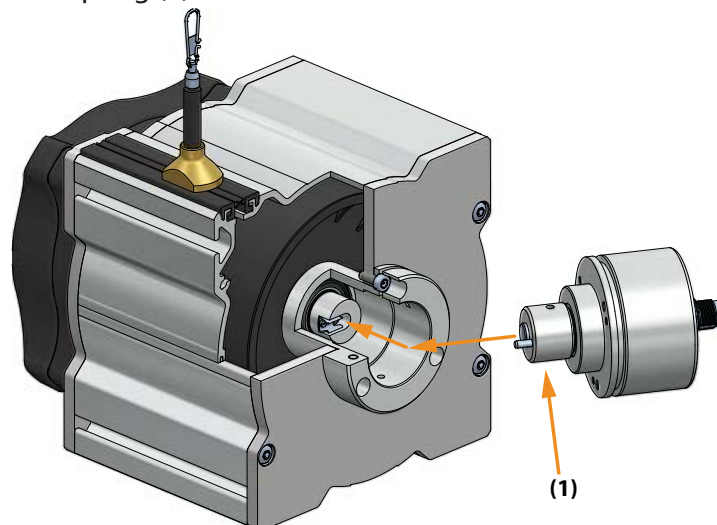

MOUNTING AN ENCODER

Easy-Clamp-Mechanism

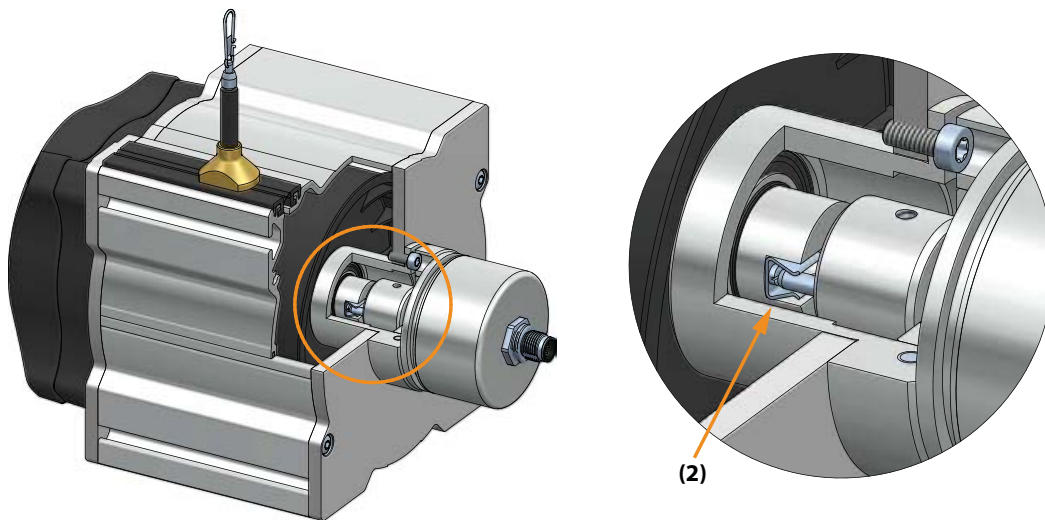

3. By tightening (1.5 Nm) the radial screw the encoder will be clamped and secured from twisting. Use a hexagon screwdriver, size 3.

The system is now ready to be mounted at the designated place.

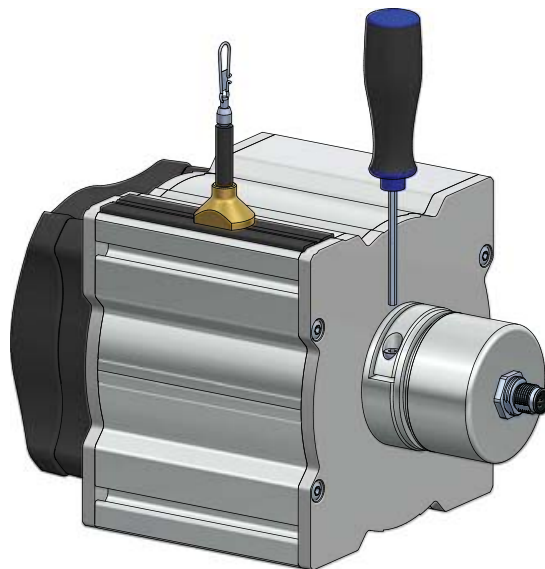

MOUNTING THE SENSOR SX80 AND SX120

Mounting standard rope outlet, rope outlet sideways top (S1)

The sensor is usually installed by using the regular mounting plate. By disassembling the mounting plate, there are 2 x M4 threads in the sensor housing for alternative installation:

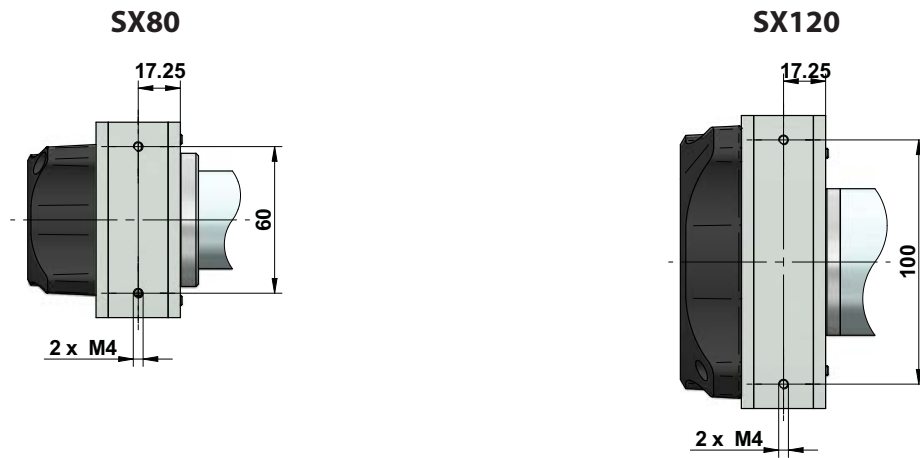

Mounting rope outlet sideways bottom (S2), rope outlet bottom (S3)

Sensors with option rope outlet S2 and S3 have a modified base plate:

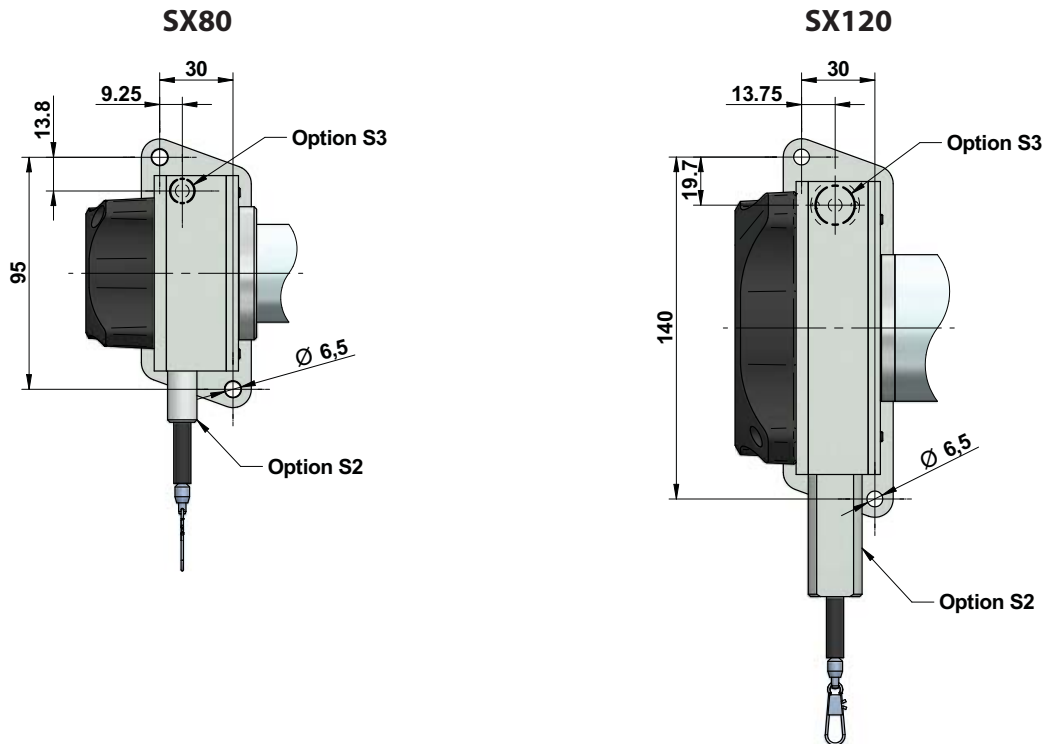

MOUNTING THE SENSOR SX135

1. Mounting via T-slot nuts

The included T-slot nuts can be easily inserted into the grooves of the sensor housing. The nuts have a metric thread M6.

Two (up to 20 m measurement range) or four (more than 25 m measurement range) T-slot nuts are included in the delivery.

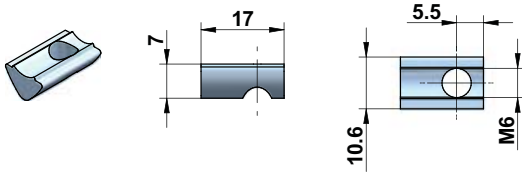

2. Mounting via angle clamp brackets

The angle clamp brackets feature a bore for M6 screws to fix it on a plate, slab or a profile.

Two (up to 20 m measurement range) or four (more than 25 m measurement range) angle clamp brackets are included in the delivery.

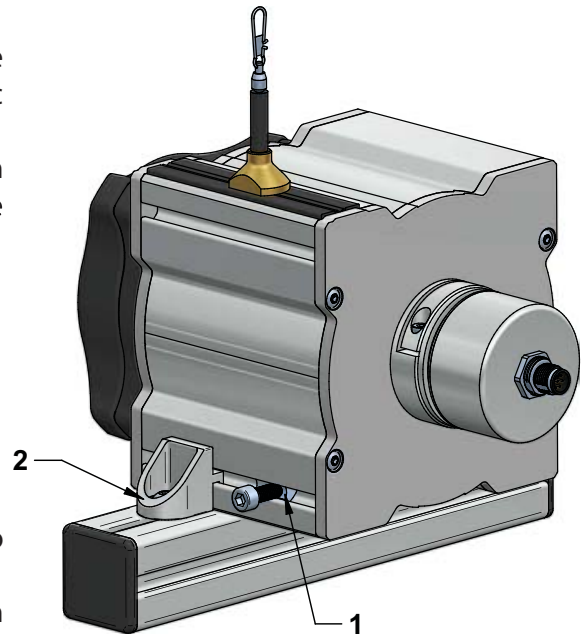
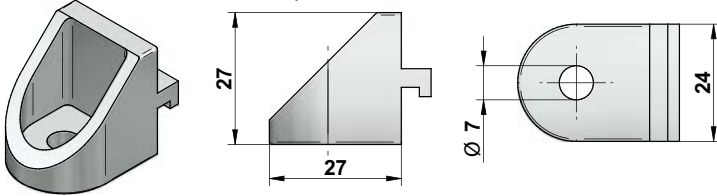

Position of the grooves and angle clamp brackets

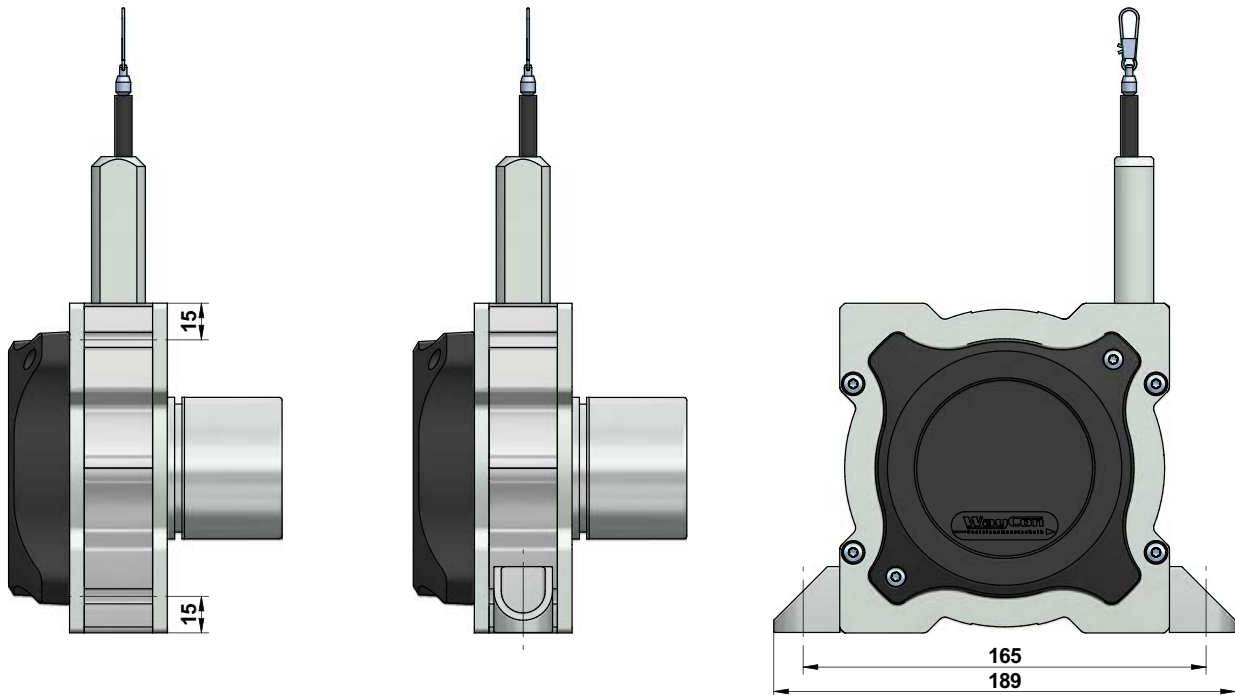



WARNING NOTICES

- Do not try to open the device. The stored energy of the spring drive may lead to injuries when being mishandled.
- Do not touch the rope when operating the sensor.
- When mounting outdoors protect the sensor and the rope from icing at temperatures below 0 °C. The usage of a deflection pulley may help defrosting the wire rope.
- When operating the sensor in a humid environment, install the sensor with the rope outlet downwards. Otherwise water will gather inside the housing, which leads to corrosion. Where applicable use option S3.

MAINTENANCE

The devices are maintenance-free. If however, the rope is soiled due to adverse environmental conditions, it can be cleaned with a cloth drenched in resin-free machine oil.

DECLARATION OF EU-CONFORMITY

This is to certify that the products

Classification	draw wire sensors
Product series	SX

fulfill the current request of the following EU-directives:

EMC-directive	2004/108/EC (until April 19th, 2016)
	2014/30/EU (from April 20th, 2016)

applied harmonized standards:

IEC 61326-1:2013

The declaration of conformity loses its validity if the product is misused or modified without proper authorization.

P3 America, Inc.
7696 183A, Unit 7B
Leander TX78641

Phone: (512) 337-7336
Fax: (858) 225-0439

Subject to change without prior notice.